

E-books



Obiettivo della lezione

- Cosa sono i libri digitali
- Progettare e costruire un e-book
- Formati standard
- Strumenti software
- Distribuzione e politiche di prezzo

Cos'è un libro?

- Sequenza di fogli manoscritti o stampati, della stessa misura, cuciti (rilegati) insieme e protetti da una copertina
 - è facile da trasportare (uno alla volta)
 - è immutabile ma annotabile
 - si può comprare, si può prestare

Cos'è un e-book?

- Un **dispositivo hardware** (“*ebook device*”) che contiene e visualizza documenti digitali che rappresentano libri o periodici
- Un **documento software**, in qualche **formato standard**, che per essere fruito ha bisogno di un programma visualizzatore (“reader” o “browser”)

Le problematiche degli ebook

- Le tecnologie di riferimento
- La creazione di contenuti
- La vendita di ebook
- I canali di distribuzione on line
- Le comunità di autori e lettori

Tipi diversi di ebook

- Servizio via web
 - Visione pagina per pagina
 - Di solito pdf su licenza a biblioteche
- E-book download semplice
 - Formati multipli
- E-book download con DRM
 - rich content
 - Di solito testi tecnici
- Audiobook

“VIEW”

“HAVE”

“USE”

“HEAR”

La tecnologia è complessa e variegata

- Molti tipi di contenuti
 - Consumo, Reference, testi, riviste
- Molti fornitori
- Molti formati e tipi di protezione (DRM)
 - ePDF, pPDF, OEB, Lit, Mobi, MP3, MP4...
- Molti canali di distribuzione
- Molti modelli economici
 - abbonamento, prestito, pay-per-view,...
- Molte piattaforme di fruizione



La filiera: molti intermediari

Ciascuno ha il suo ruolo

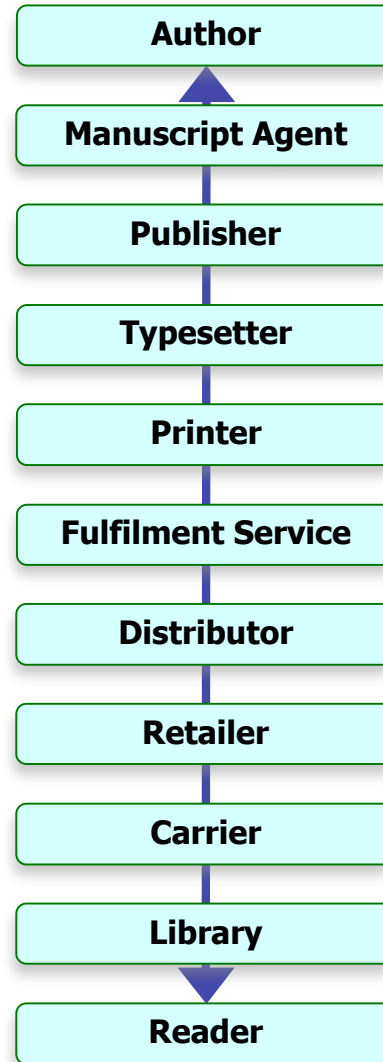

Disintermediazione



La tecnologia

- Hardware dedicato (es. Gemstar)
- E-paper (es. Sony Librie)
- Software
 - Su PC o Macintosh
 - Su palmare: Palm e PocketPC
 - Su TabletPC
 - Su Iphone

Dispositivi hardware

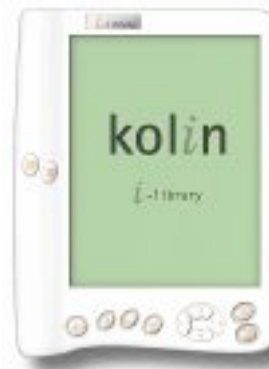

NB: Alcuni di questi dispositivi sono oggi fuori mercato

Gemstar

- Comprò RocketBook e SoftBook
- Ha abbandonato il mercato ebook hw
- Pubblica TV Guide



REB1100 e REB1200



- Fabbricante: RCA
- 1100: 500g, B&W, \$299 (Rocket)
- 1200: 1Kg, VGA, \$699 (Softbook)
 - Touch screen
 - Modem

Fuori mercato dal giugno '03

Chapter 1 Carbon



Atomic Data for Carbon
Strong Lines for Carbon
Persistent Lines of Neutral Carbon
Persistent Lines of Singly Ionized Carbon
Energy Levels of Neutral Carbon
Energy Levels of Singly Ionized Carbon
References for Carbon



| Main |



Rocket Writer

Transfer electronic documents and take them with you on the Rocket ebook.



Inter-Office Memos



Marketing Plans



Websites



Proposals



E-mail

any
text & graphics



Softbook



**Powerful reading
and word search
tools**

**Highlight
important
sections**

**Make notes and
annotations**

**Built-in phone line or
Ethernet connection for
anytime, anywhere connectivity.**

**Tap screen to
bookmark page**

**Turn pages
backward or
forward**

**Expand storage
capacity with
CompactFlash
Cards**

**See current page
number and bookmarked
pages**

Sigma Book

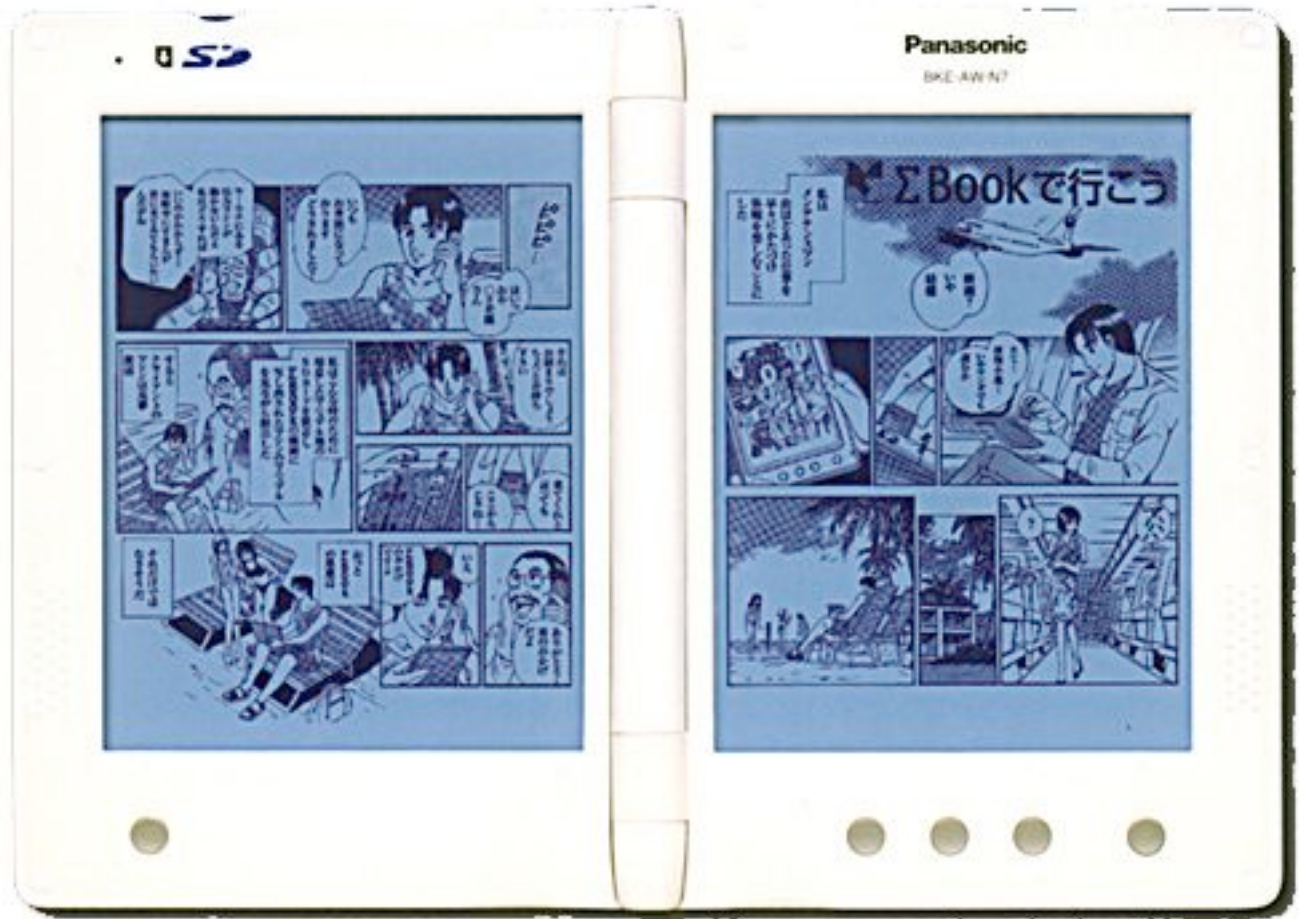

Librie

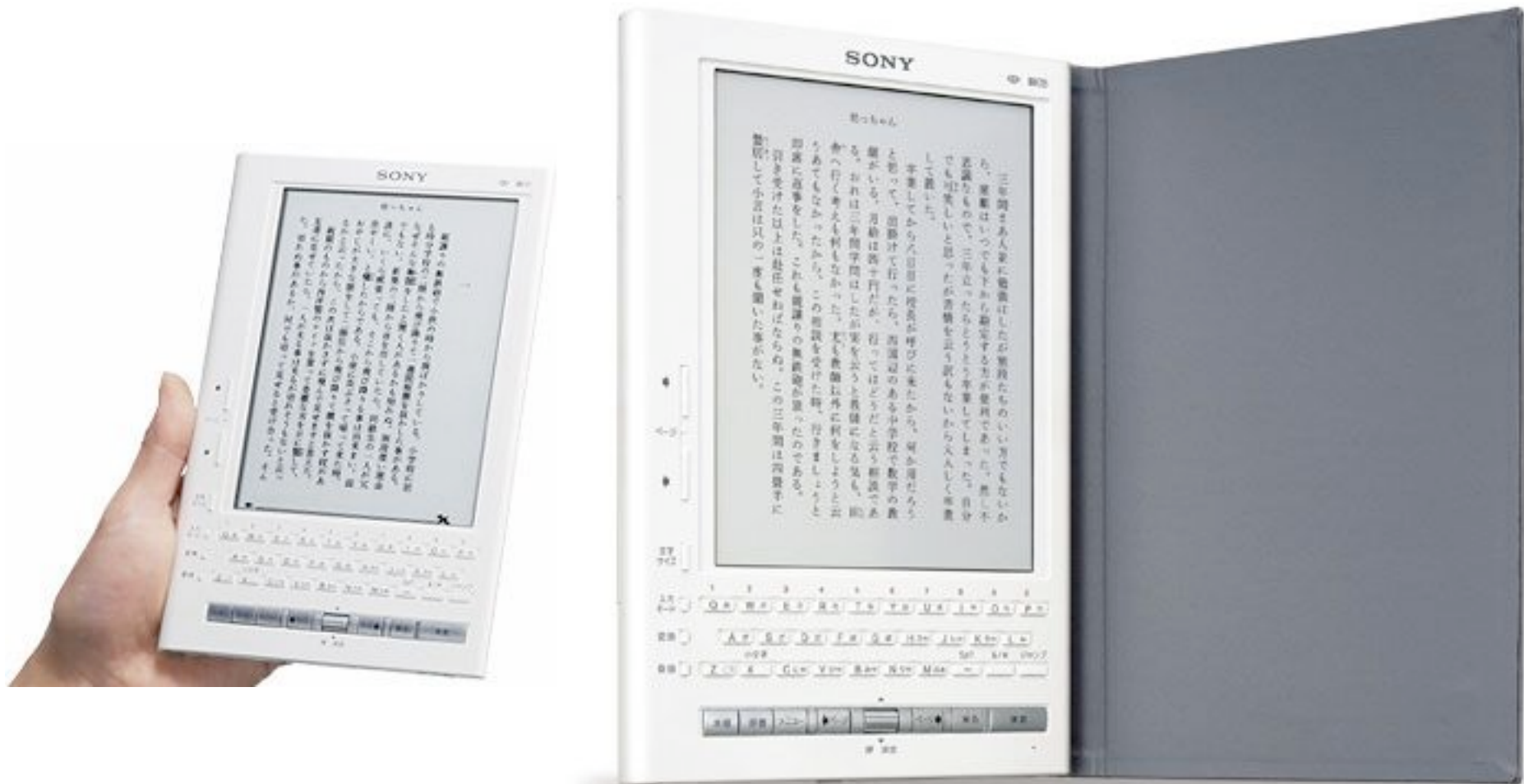

Sony Reader

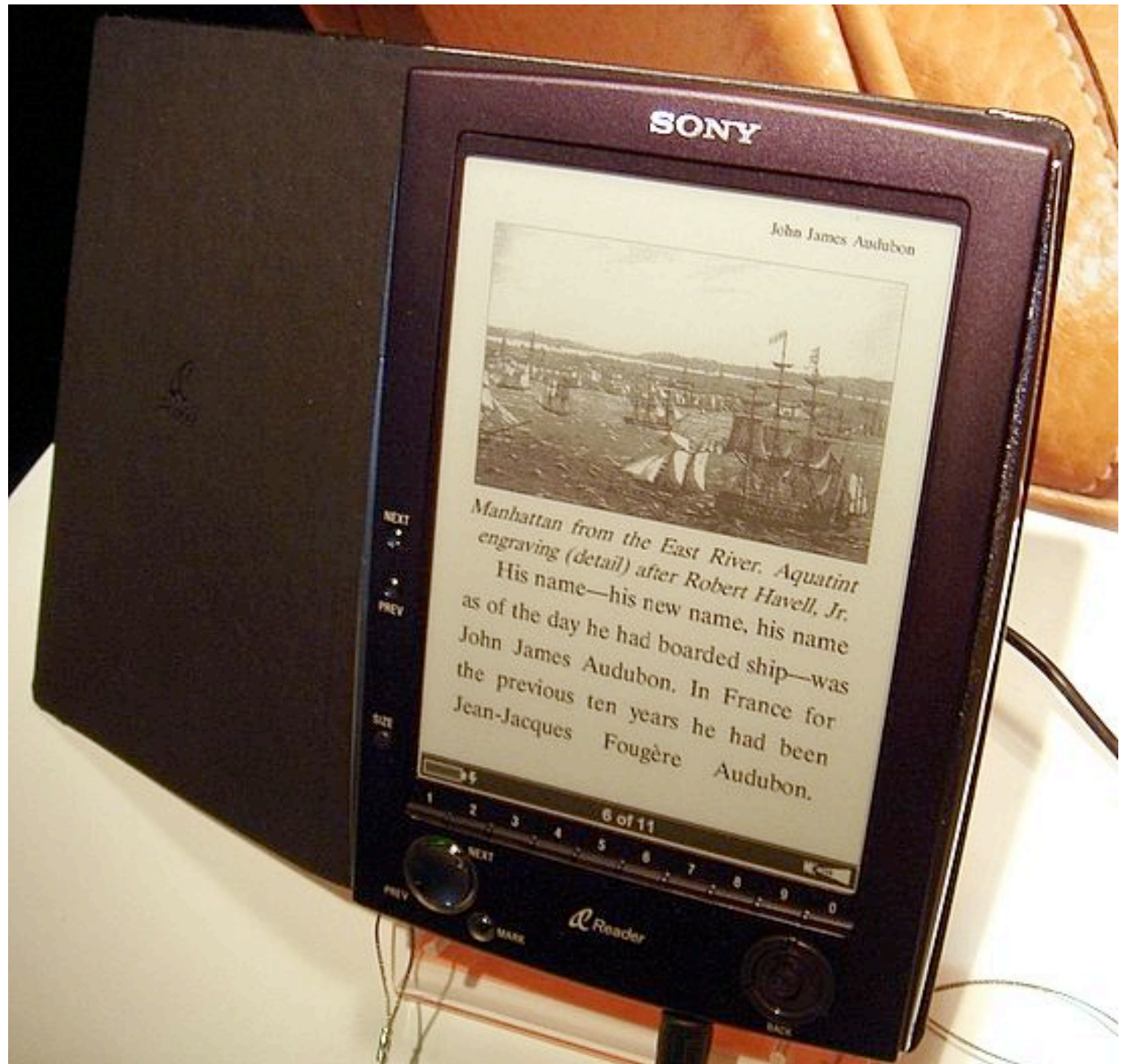

E-paper & e-ink

- E-ink: un 'inchiostro' di microcellule programmabili che formano i caratteri, inserito all'interno di un supporto flessibile (e-paper)

Cross-Section of Electronic-Ink Microcapsules

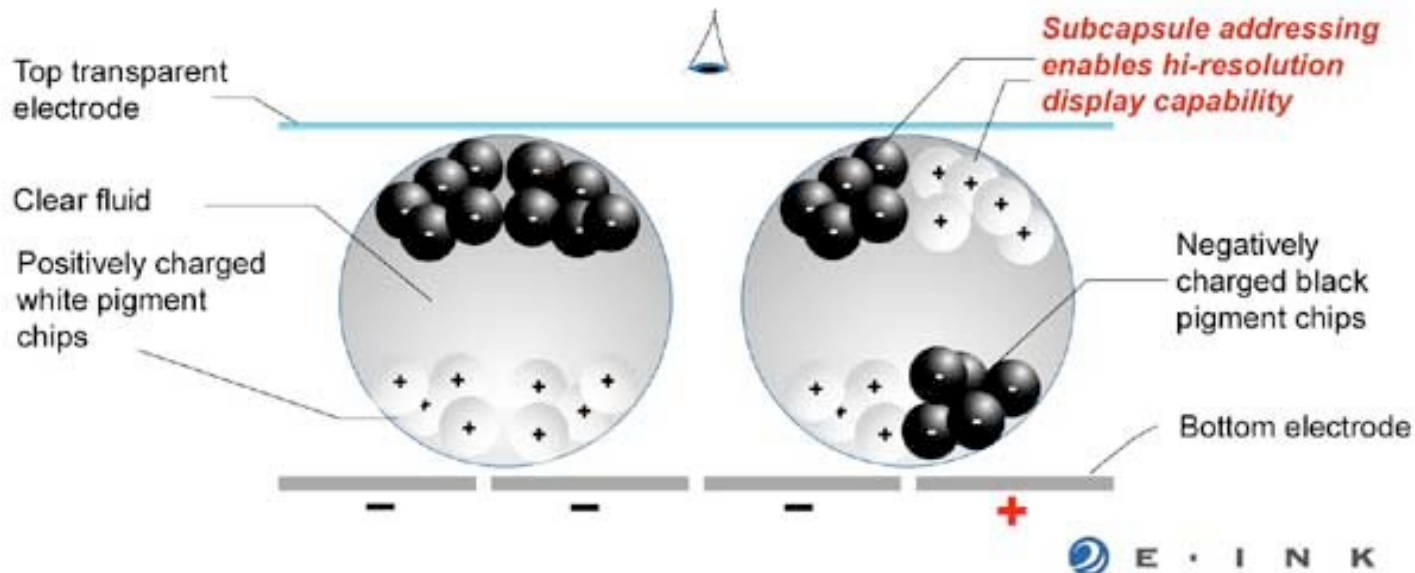

Philips E-ink

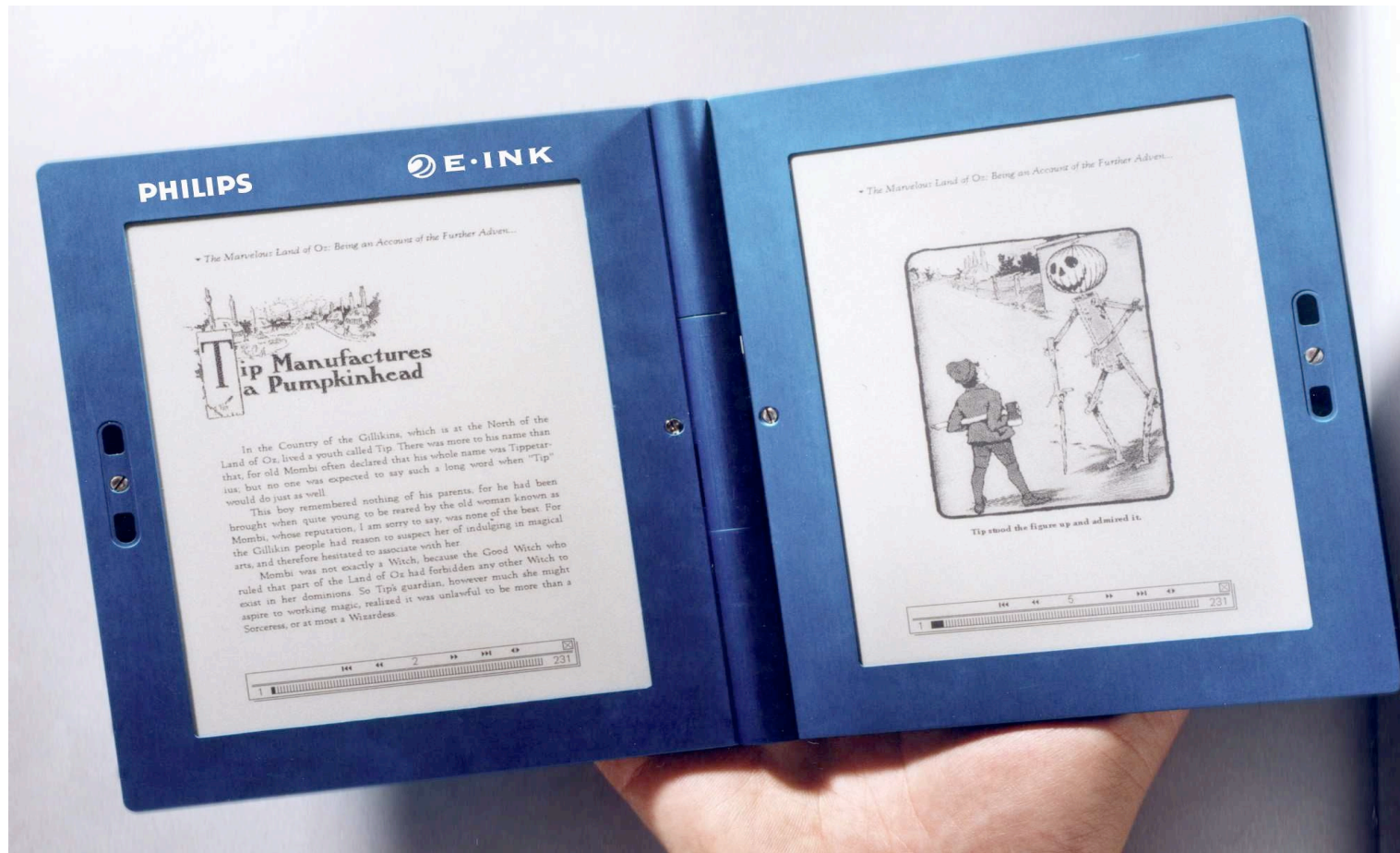

Una copertina con e-ink

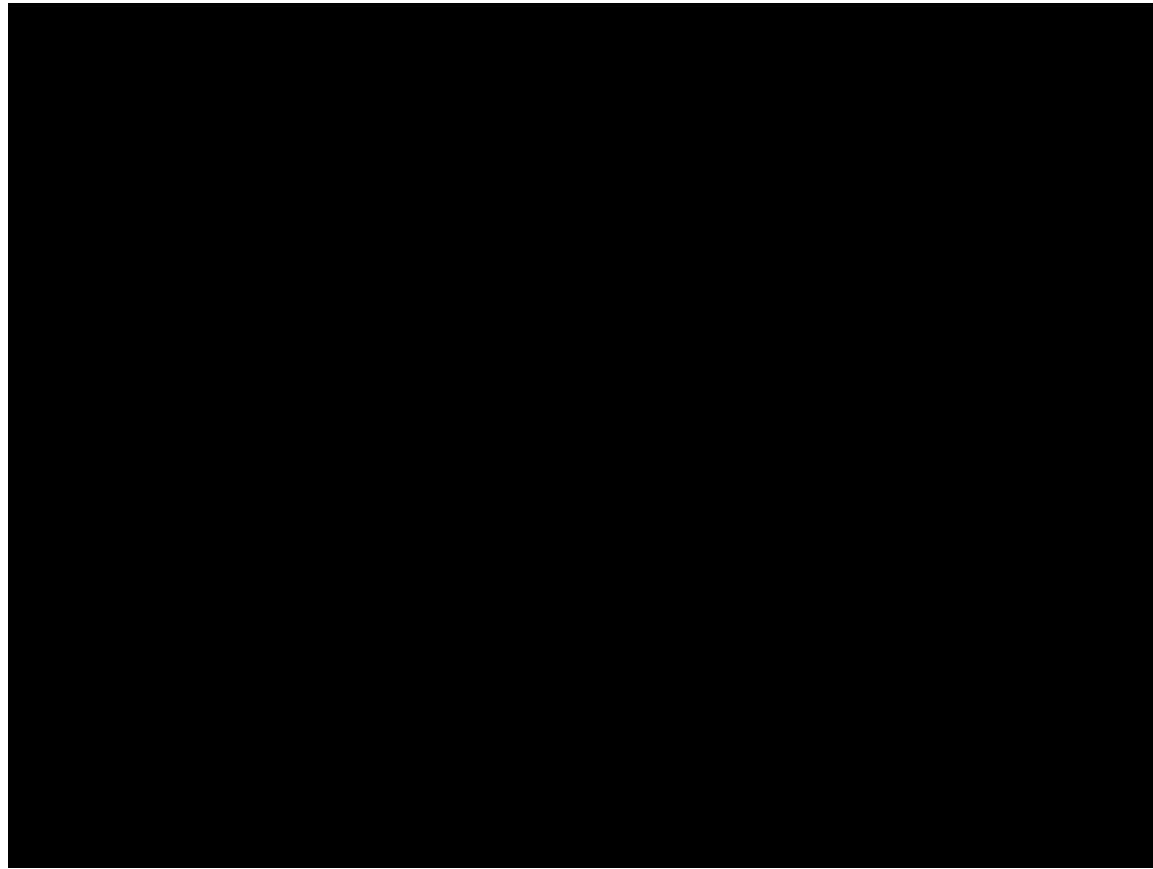

Esquire sett 2008

Caratteristiche

- Gli ebook basati su eink sono i più diffusi
- Hanno bisogno di luce esterna per essere letti: più ce n'è meglio è
- Grande autonomia con una carica: 7000-10000 pagine per carica
- Non adatti per navigazione internet
- Molti sono lettori mp3 (musica e audiolibri)

Radius



BeBook

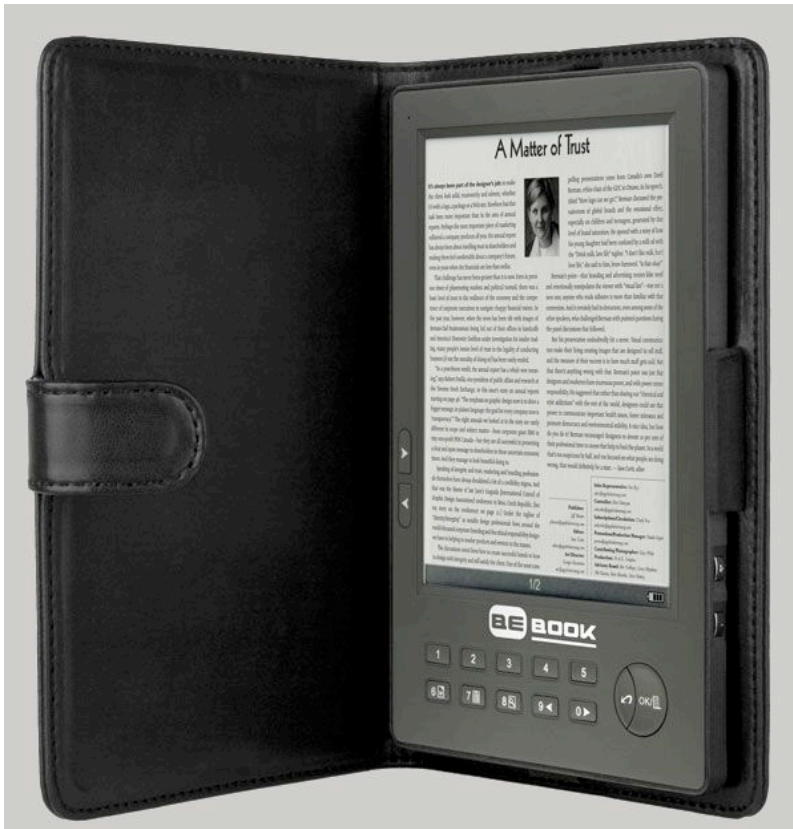

- BeBook supporta i formati pdf, djvu, mobi, lit, epub, doc, html, txt, prc, fb2, jpg
- 512MB espandibili con schede fino a 4GB
- 300€
- BeBook2: estate 2009, aggiunge schermo touch e connessione WiFi

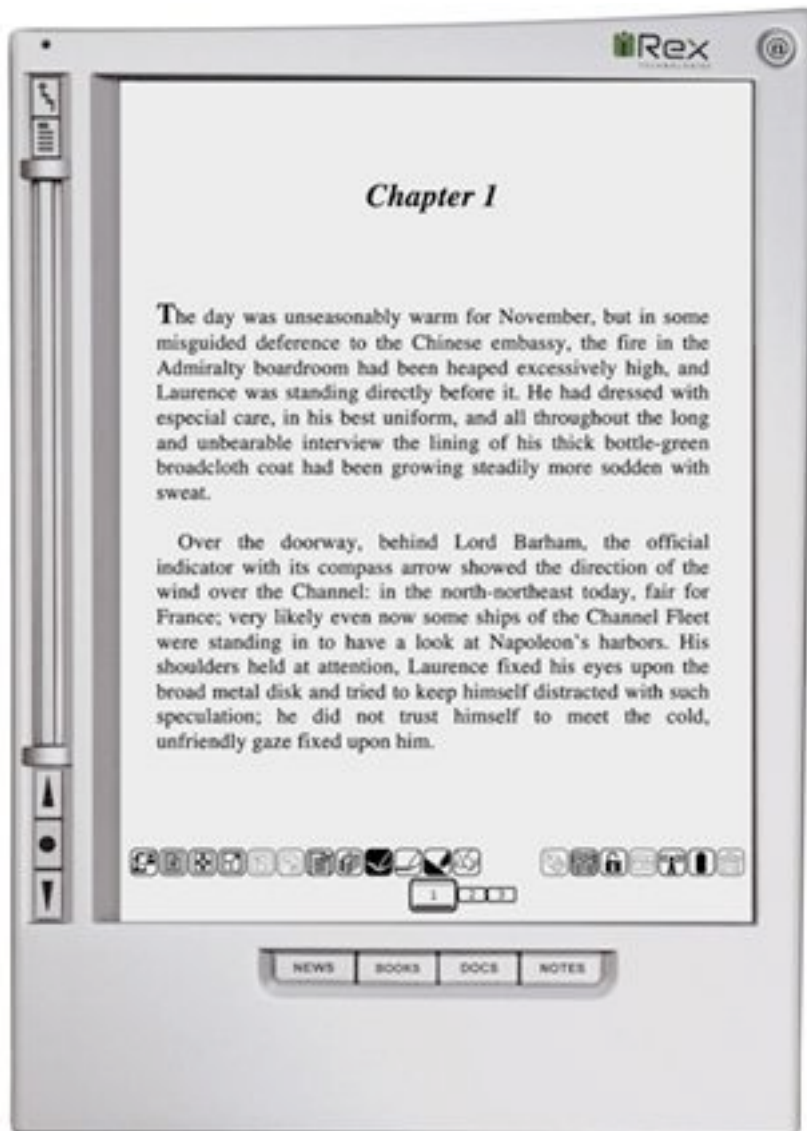

Iliad

- Brevetto olandese
- Grande schermo
- Due modelli: Iliad e Iliad Book Edition
- Formati: pdf,html, txt, mobi/prc
- Tra 500 e 600€

www.irextechnologies.com

Kindle1 (Amazon)



- Uscito a fine 2007
- 400\$
- Vari formati, ma non PDF
- Connettività cellulare

Sony Reader vs Kindle1

Reader vs. Kindle

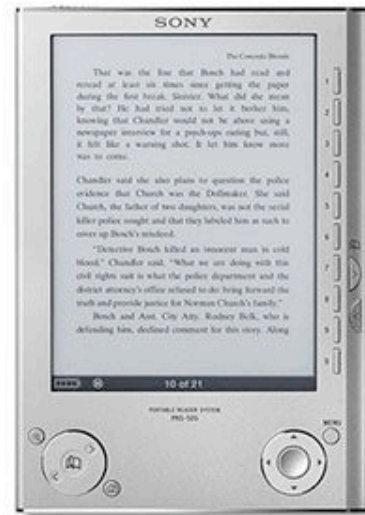

\$300

No Internet Connectivity
View PDF, TXT, RTF, DOC free of charge
Free blogs
Free RSS
Play MP3 Files
192 MB Storage
Memory Stick/SD Card Slot



\$400

EVDO Internet
\$0.10 per-file fee to view own files
\$1 for each blog
\$1 for each RSS feed
No Audio
"Holds over 200 titles"
SD Card Slot
Wikipedia
Dictionary

Kindle 2



Kindle 2

- Disponibile solo in USA, autunno 2008
- Schermo 6", memoria 2Gbyte, wireless cellulare 3G
- 359\$ nuovo, 250\$ usato
- Disponibili 275K libri, centinaia di giornali
- Best seller correnti a 10\$ l'uno
- Formato proprietario; pdf se convertiti online

en.wikipedia.org/wiki/Amazon_Kindle

Kindle DX

- Disponibile da estate 2009
- Schermo 9.7"
- 4Gbyte (≈3.500 libri)
- Gestione pdf nativa
- Wireless cellulare 3G
- 489\$



Conclusioni su lettori e-ink

- Tecnologia in evoluzione
- Interfaccia in evoluzione
- Prodotti forse cari rispetto alle funzioni che offrono
- Si paga soprattutto la dimensione dello schermo
- Leggeri
- Si leggono in pieno sole
- Espandibili con memorie flash economiche

Portatili, palmari e telefoni

- Costosi
- Pesanti
- Retroilluminati
- Ottima interfaccia
- Alta capacità di memoria
- Possibilità di software alternativo

Tablet PC



- Tecnologia touch screen per laptop
- Sistema operativo Windows speciale
- Lettori software

Palmari

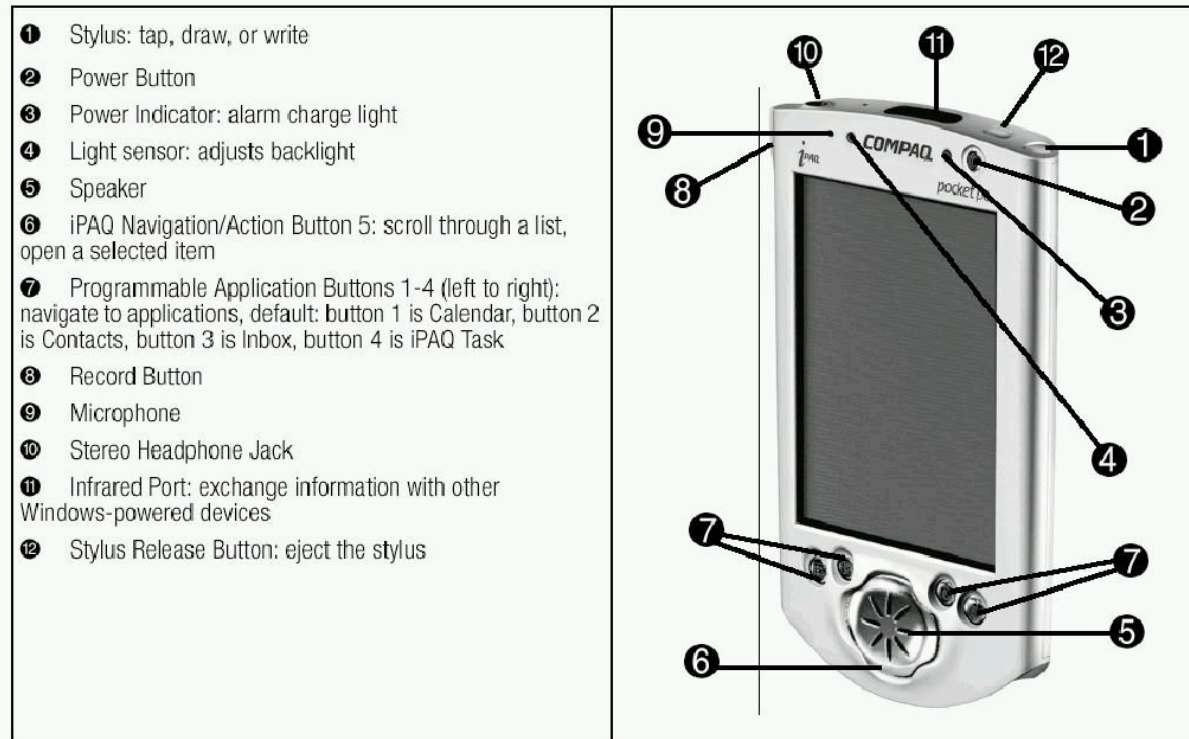

- Palm OS e Windows CE
- Hardware speciale + lettori software
- Touchscreen, memoria limitata

Palmari: Ebookman

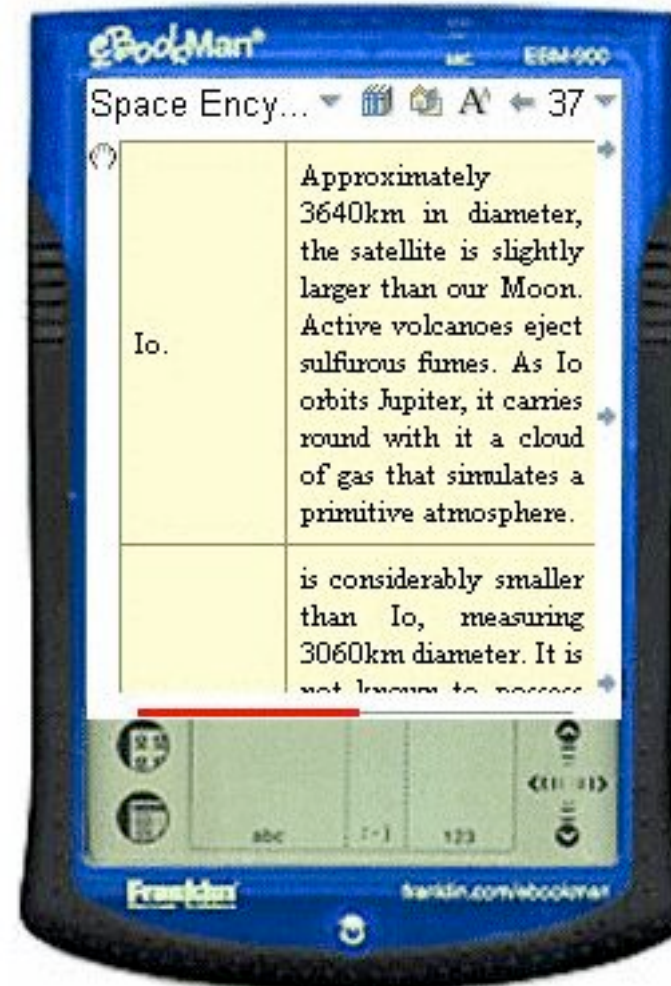

Palmasi: hiebook



Smartphones



- Ogni telefonino con schermo abbastanza grande può ospitare ebook
- Formato: plucker, ovvero html semplificato

Ipod

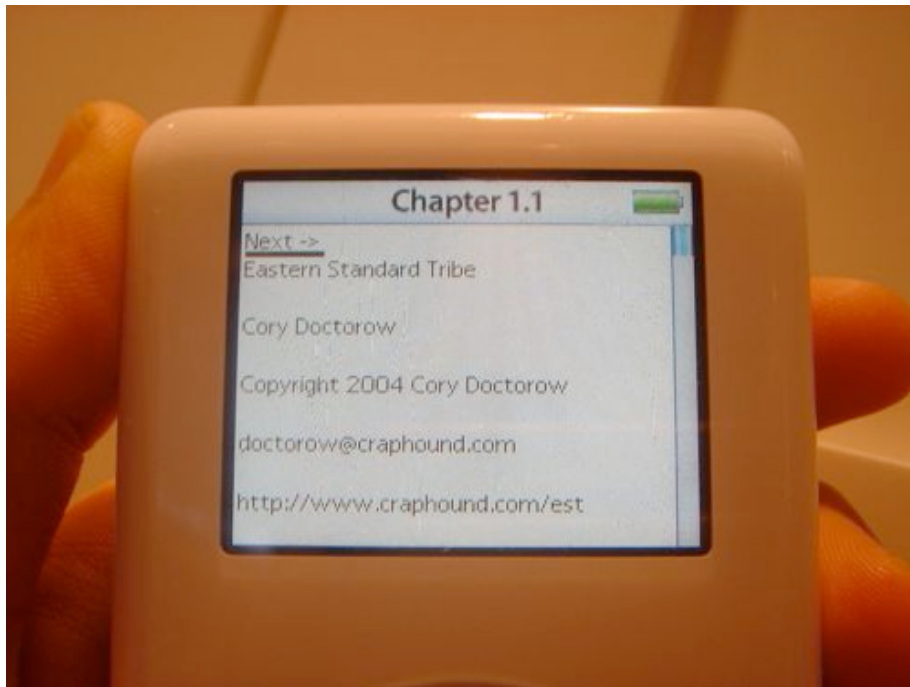

- Lettore libri audio mp3
- Lettore libri "Notes"
- Grande capacità di memoria
- Schermo troppo piccolo
- Necessita di sw di supporto (iTunes) su Windows o Macintosh

Iphone (e Ipod Touch)

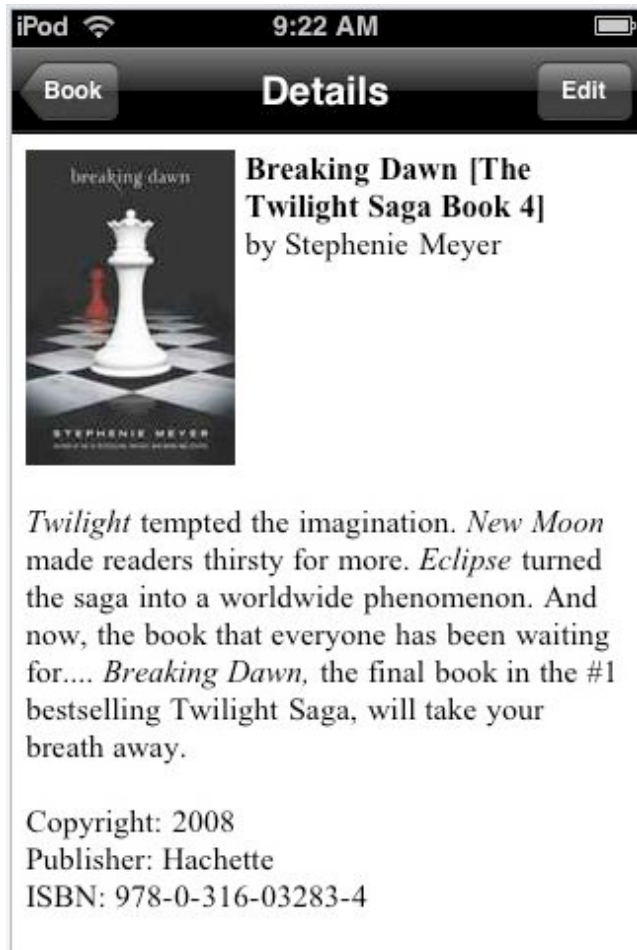

ereader

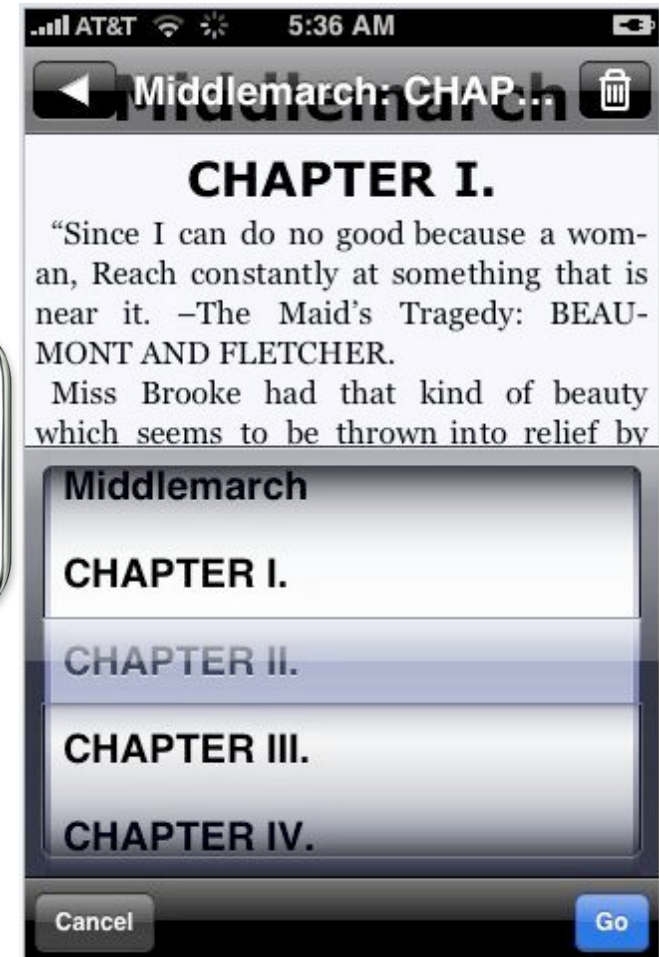
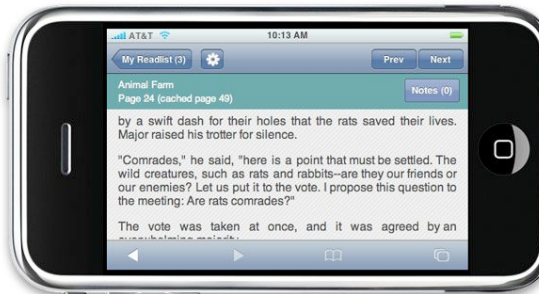

Stanza

Stanza su Iphone

- Stanza è un'applicazione e-reader su Iphone e Ipod touch
- Permette di scaricare dalla rete o dal proprio PC libri di vari formati (incluso pdf!)
- E' un ottimo convertitore di formato



www.lexcycle.com

Ebook software

- Sono documenti digitali leggibili con programmi specifici (“ebook sw reader”)
- Hanno formati speciali "ebook".
Es.: .epub
- In genere un ebook rappresenta un'opera completa ed è corredato di *servizi* utili alla lettura ed alla protezione dei contenuti

I "lettori" software (reader)

Es. Acrobat / Microsoft / Palm Reader

- Formato specifico
 - .pdf o .lit o .pdb
- Interfaccia minimale per la lettura
- Alta leggibilità grazie a ricchezza tipografica
- Contenuto sia libero che protetto
- Funzionalità per il commercio elettronico
 - Autenticazione di proprietà
 - Controllo dei servizi accessori
 - DRM (Digital Rights Management)

Lettori software

- Adobe Acrobat Reader (per pdf)
- Adobe Digital Edition (per epub)
- Microsoft Reader (per .lit)
- Mobipocket (per .mobi)
- Sophie, Zinio, TK3, eccetera

Ebook come “pratica”

**“Non si possiede un libro
se non si possiede
la sua versione ebook”**

Cory Doctorow

E-book come “pratica”

- Un ebook può essere collezionato
- Un ebook può essere scambiato, prestato, comprato, venduto
- Un ebook può essere duplicato
- Un ebook può essere annotato
- Un ebook può essere convertito per canali diversi, per es. stampato

Alcuni siti per ebook

- Classici italiani www.letteraturaitaliana.net
- Progetto Manuzio www.liberliber.it
- Progetto Gutenberg www.gutenberg.org
- Microsoft Lit www.msLit.com/
- Sito manybooks Manybooks.net
- WOWIO
- Cory Doctorow pubblica e-book su craphound.com: li offre gratis con diritti protetti da licenza Creative Commons (e fa soldi comunque vendendo le copie cartacee!)

Liberliber.it

ti trovi in: [Copertina](#) > [Home](#) > [Biblioteca](#) > [Statistiche](#) >

Aprile 2007



I venti "e-book" più scaricati dal sito Web di Liber Liber. Dati relativi a: vedi sopra. È possibile consultare i dati degli [altri mesi](#).

1. **Illiade**, di [Homerus](#) (Omero)
2. **Sulla origine delle specie per elezione naturale, ovvero conservazione delle razze perfezionate nella lotta per l'esistenza**, di [Charles Darwin](#)
3. **Divina Commedia**, di [Dante Alighieri](#)
4. **I promessi sposi**, di [Alessandro Manzoni](#)
5. **Aforismi, novelle e profezie**, di [Leonardo](#)
6. **Internet 2004**, di [M. Calvo](#), [F. Ciotti](#), [G. Roncaglia](#), [M. A. Zela](#)
7. **Odissea**, di [Homerus](#) (Omero)
8. **Anna Karenina**, di [Lev Tolstoj](#)
9. **Così è (se vi pare)**, di [Luigi Pirandello](#)
10. **Sogno di una notte di mezza estate**, di [William Shakespeare](#)
11. **Il fu Mattia Pascal**, di [Luigi Pirandello](#)
12. **Trattato della Pittura**, di [Leonardo](#)
13. **Romeo e Giulietta**, di [William Shakespeare](#)
14. **Corano**, vedi [Corano](#)
15. **La Sacra Bibbia**, vedi [Bibbia](#)
16. **Giulio Cesare**, di [William Shakespeare](#)
17. **Jolanda, la figlia del corsaro nero**, di [Emilio Salgari](#)
18. **La coscienza di Zeno**, di [Italo Svevo](#)
19. **Don Chisciotte della Mancia**, di [Miguel de Cervantes](#)
20. **Novelle per un anno**, di [Luigi Pirandello](#)



- Leggere un ebook online
- Oppure scaricare pdf a pagamento

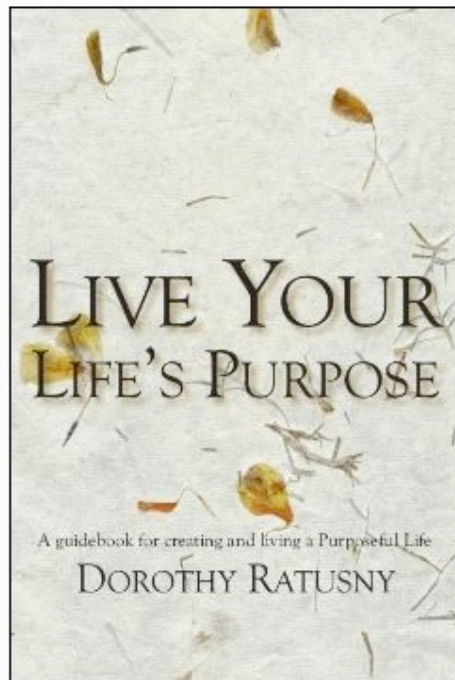



Live Your Life's Purpose

Dorothy Ratusny

182 pages (10/16/2008); 1.1MB download

Insomniac Press; ISBN: 978-1-897415-34-4

 Read Online Free

 Add to Library

 Download PDF \$0.99 (USD)

 Send PDF as Gift \$0.99 (USD) — With Free Gift Wrapping

READERS OF THIS BOOK ALSO VIEWED

[Sex Secrets: A Husband's Guide to Lovemaking](#), Frank Cupidon

[The Prince](#), Niccolo Machiavelli

[Your Exceptional Mind: Enhance Intelligence, Expand Understanding](#), Robert Flower

[Eloise: Letters to a Lost Child](#), Loise Lavallee

[The 60 Second Procrastinator: Sixty Solid Techniques to Jump-Start Any Project and Get Your Life in Gear!](#), Jeff Davidson

Alcuni distributori on line

- www.gutenberg.org
- Amazon.com
- Barnes&Noble.com www.book.com
- www.overdrive.com
- www.apogeeonline.it
- www.ebookmall.com/
- Blackmask Online www.blackmask.com
- CEWindows.NET www.cewindows.net
- DotLit dotlit.com
- Elegant Solutions Sw and Publishing esspc-ebooks.com
- eText Center etext.lib.virginia.edu
- Spanish University of Distance Education liberuned.com
- Bibliotheque Nationale de France gallica.bnf.fr
- Fictionwise www.fictionwise.com
- Hard Shell www.hardshell.com/ebooks.html
- MemoWare www.memoware.com
- On-line Books Page digital.library.upenn.edu/books
- Pocket PC eBooks Watch Books.blogspot.com
- PocketPCpress www.pocketpcpress.com
- Reader's Central
- Bitbooks
- eBookAd.com
- Powells.com

Filiere a confronto

Filiera del libro

- Autori e agenti
- Editore cartaceo
- Cartiera
- Produttori di macchine tipografiche
- Stampatore
- Distributore
- Grossista
- Libreria

Filiera dell'ebook

- Autori e agenti
- Editore digitale
- Produttori di hw e sw di visualizzazione
- Produttori di sw di conversione formati
- Service di conversione
- Service DRM
- Sito di e-commerce

Esempio: elibra

- Elibra vende un servizio DRM
- Permette agli autori di vendere direttamente o tramite intermediario

www.starpath.com/elibra/

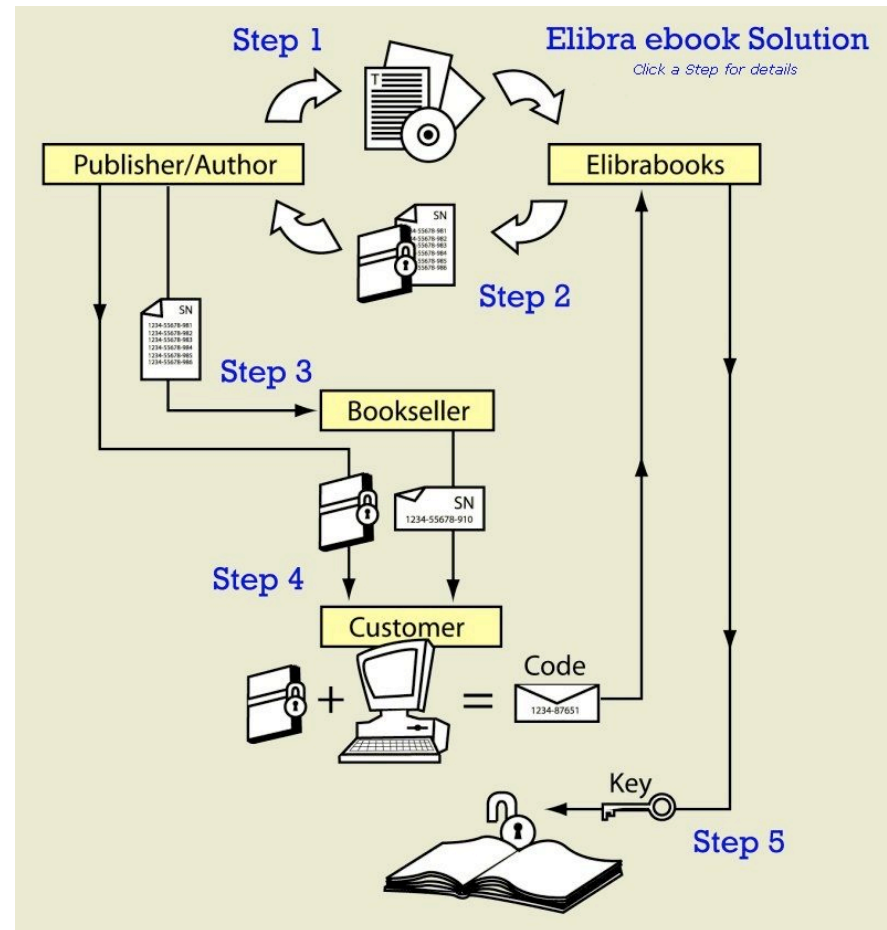

Publicare un Ebook vs pubblicare un sito Web

- Vantaggi degli ebook
 - Pubblicazione on line semplice
 - Contenuto "impacchettato", facile da scaricare tutto
 - Gestione veloce ed economica
 - Gestione dei diritti di proprietà intellettuale
- Svantaggi degli ebook
 - Nessuno standard di formato dominante
 - Minore interattività rispetto ai siti
 - Costo per il fruitore (occorre browser speciale)
 - Come si organizza una biblioteca di ebook?

Motivazioni editoriali

- Convenienza economica
- Vantaggio competitivo (early to market)
- Mercato in crescita degli utenti abituati a cercare informazioni on line
- Aggiornamenti
- Personalizzabilità dei diritti di fruizione

Letteratura tecnica

[Home](#) [Products](#) [Solutions](#) [Feedback](#) [About Us](#) [Log In](#)



Referenceware
Bridging the Knowledge Gap

[Learn More](#)

[> My Home](#)

[> Take the virtual tour](#)

[> Sign Up](#)
Subscription Trial

[> View New Collections](#)
ExecBlueprints
EngineeringPro
ExecSummaries

Bridging the gap between what you know and...

Referenceware® is the largest online book resource offering unobstructed access to the complete unabridged contents of thousands of the latest and best business and technology books, as well as to expert summaries of popular business books.

Professionals, across all disciplines, rely on Referenceware for continuous learning to help solve job-critical challenges and to drive corporate initiatives. Browse Referenceware's collections and learn more about the fastest way to problem-solve, learn and succeed.

“Books24x7 provides all I could possibly need.”
Software Developer, Reuters

...what you need to know to



problem - solve , learn and succeed

[Choose a collection](#)

Use of content on this site is expressly subject to the restrictions set forth in the [Membership Agreement](#).
Books24x7 and Referenceware are registered trademarks of Books24x7, Inc.
Copyright 1999-2005 Books24x7, Inc. - [Feedback](#) | [Privacy Policy](#) (updated 03/2005)

Books24x7 is a **Skillssoft** company

Letteratura di viaggio

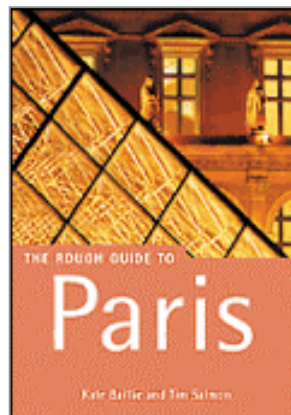
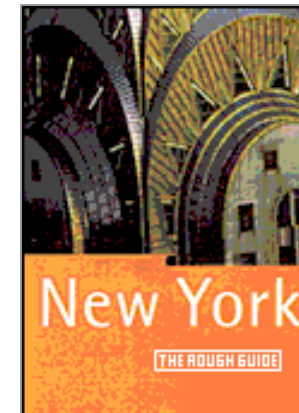
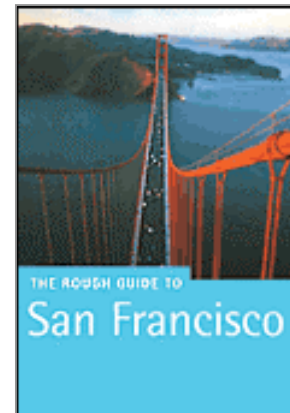
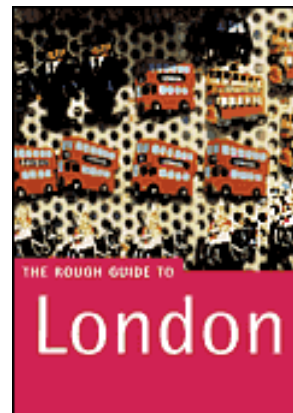

Nuovi canali e contenuti liberi

Wikitravel article discussion view source history My page my talk preferences my watchlist my contributions log in / create account

VOA News features Wikitravel as *Website of the Week*

Main Page

Wikitravel is a project to create a **free**, complete, up-to-date, and reliable **worldwide travel guide**. So far we have **21,267** destination guides and other articles written and edited by **Wikitravellers** from around the globe. Check out the **Help** page to see how you can edit any page **right now**, or the **Project** page for more information about Wikitravel and getting involved.

- Africa**
- Asia**
- Oceania**
- Europe**
- Middle East**
- North America**
- South America**
- Central America & Caribbean**
- Other destinations**
- Travel topics & Phrasebooks**

Destination of the month

Australia's sparsely-populated **Northern Territory** boasts spectacular brush landscapes in its southern **Red Centre** region, including **UNESCO World Heritage** listed **Uluru-Kata Tjuta National Park**, the famous Outback town **Alice Springs**, and much Aboriginal culture. To the north, there is the remote, yet cosmopolitan, city of **Darwin**, as well as the famous swamps and wetlands of **Kakadu National Park**. *(more...)*



Off the beaten path

Tywyn sits on 4 miles of sandy beach on the Cardigan Bay shoreline of **Wales**. While some visitors may not stray far from that beach, the more adventurous will be rewarded with a 140 year old steam railway, a crying statue, and lush green valleys and hills hiding lakes, waterfalls, a medieval castle and prehistoric fortresses. Legends tell of a nearby lost land beneath the sea, and of a visit by the mythical King Arthur. *(more...)*

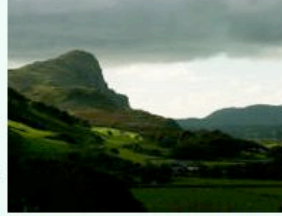

Discover

- You can cross the **Bridge over the River Kwai**, of movie fame and located in **Kanchanaburi**, on **foot** – and then ride an **elephant** (for a price, of course).
- It used to be possible for you to **tour a Soviet submarine** while visiting **Providence, Rhode Island**, but alas, the vessel **sank in a storm**.
- The fence around **Saint Petersburg's Transfiguration Cathedral** is made from **captured Ottoman cannons** from the Russo-Turkish War.

Travel alerts

- Pakistan Launches Major Offensive against Taliban** (8 May 2009)
- S. California Sees Large Wildfires** (8 May 2009)
- Violence Surges in Chad, Blamed on Sudan** (7 May 2009)
- Georgian Unrest Continues** (7 May 2009)
- Armenia, Azerbaijan Presidents Meet, Discuss Nagorno-Karabakh Situation** (7 May 2009)
- It's Death's Throes for Sri Lanka's Separatist Tamil Tigers** (23 April 2009)

Current and upcoming events

- Saint Petersburg and Pskov has a direct railway connection** (31 May 2009)
- Swansea Bay Film Festival** (30 May - 6 June 2009)
- Sayonara, Mickey Mouse Revue** (25 May 2009)
- Scotland Regains Direct Ferry From Continental Europe** (18 May 2009)
- A new seaport of Saint Petersburg** (4 May 2009)
- Saint Petersburg's Marble Palace opens its Winter Garden** (24 April 2009)

Other languages

Featured Articles

New "Star" Articles

- Sheki
- SF/Golden Gate
- SF/Civic Center-Tenderloin

We're collaborating to improve

Copenhagen

Books from Wikitravel Press

Cairo [↗](#), Paris [↗](#), Chicago [↗](#), [more ↗](#)

More on Wikitravel Extra [↗](#)

[blogs ↗](#), [forum ↗](#), [photos ↗](#)

navigation

- Main Page
- Project Home
- Travellers' Pub
- Recent changes
- Random page
- Help
- Wikitravel Shared
- Wikitravel Extra

feeds

- Travel news and trivia

search

toolbox

- What links here
- Related changes
- Don't upload file
- Special pages
- Printable version
- Permanent link

in other languages

- ar: الصفحة الرئيسية
- ca: Pàgina principal
- de: Hauptseite
- eo: Ĉefpaĝo
- es: Portada
- fr: Accueil
- fi: Etusivu
- he: עמוד ראשי
- hi: मुखपृष्ठ
- hu: Kezdőlap
- it: Pagina principale
- ja: メインページ
- nl: Hoofdpagina
- pl: Strona główna
- pt: Página principal
- ro: Portal
- ru: Заглавная страница
- sv: Huvudsida
- zh: 首页

other sites

- Wikitravel Shared
- World66
- Wikipedia
- Open Directory
- Wikevent
- wikiHow

Letteratura di scacchi

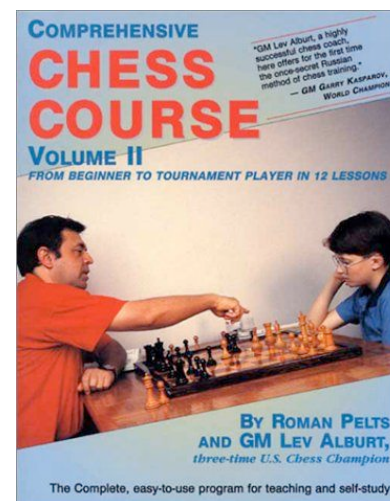
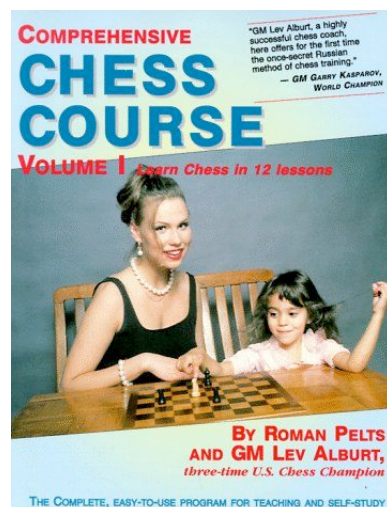
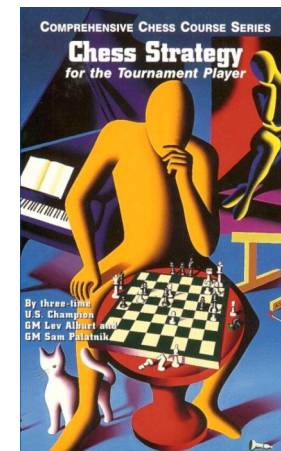
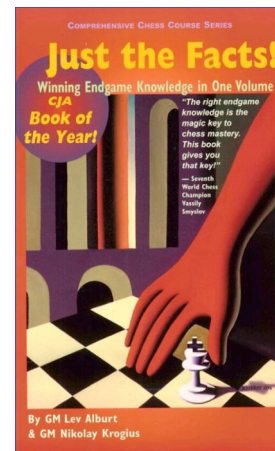
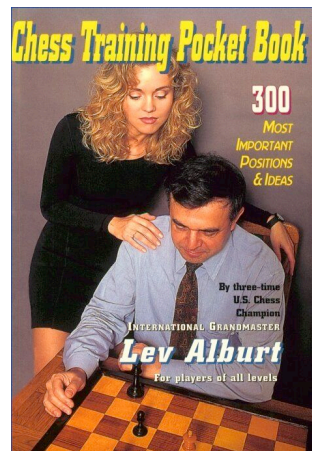
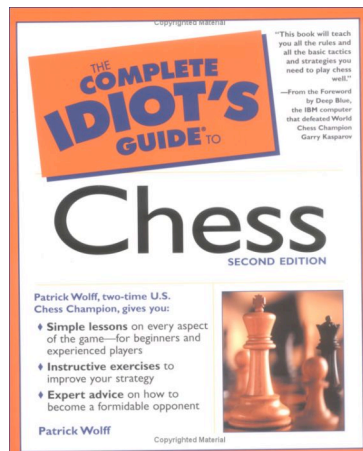

Mobipocket.com



[My Bookshelf](#) | [Cart](#) | [Support & Forum](#)

English
BESTSELLERS NEW TITLES Search eBook Go
My Recommendations

Search eBooks

Find eBooks by Title, Author or Keyword

Go

[Advanced Search](#)

Browse

[Authors](#)

[Browse Series](#)

Fiction eBooks

- [General Fiction](#)
- [Science Fiction](#)
- [Romance](#)
- [Fantasy](#)
- [Suspense & Thrillers](#)
- [Action & Adventure](#)
- [Mystery & Crime](#)
- [Erotica](#)
- [Classics](#)
- [Historical Fiction](#)
- [Juvenile Fiction](#)
- [Novels](#)
- [Horror](#)
- [Humor](#)
- [Cartoons](#)
- [Movies & TV Series](#)
- [Religious Fiction](#)
- [Tales & Fables](#)
- [Short Stories](#)
- [True Crime](#)
- [Poetry](#)
- [Theatre](#)
- [Star Trek](#)

Non fiction eBooks

- [Medical](#)
- [Dictionaries](#)
- [Spiritual & Religion](#)
- [Self-Improvement](#)
- [Psychology](#)
- [Health](#)
- [History](#)
- [Politics](#)
- [Biographies](#)
- [Current Events](#)
- [Encyclopedias](#)
- [Travel](#)
- [Family](#)

Welcome to Mobipocket.com. **First time user?**



Buy **Collins Unabridged English Dictionary, 9th edition** **\$34.99.**
and get **Collins Thesaurus** for **Free.**

EBOOKS [Special Offers](#) [Below Print book Price](#)

<p>Short Stories</p>  <p>\$13.00</p>	<p>Politics</p>  <p>\$0.99</p>	<p>General Fiction</p>  <p>\$26.99</p>	<p>Romance</p>  <p>\$7.20</p>
<p>Psychology</p>  <p>\$24.99</p>	<p>Movies & TV Series</p>  <p>\$16.00</p>	<p>General Fiction</p>  <p>\$26.00</p>	<p>Juvenile Fiction</p>  <p>\$6.99</p>
<p>Suspense & Thrillers</p>  <p>\$24.99</p>	<p>Juvenile Fiction</p>  <p>\$6.99</p>	<p>Juvenile Fiction</p>  <p>\$5.99</p>	<p>Juvenile Fiction</p>  <p>\$6.99</p>
<p>Juvenile Fiction</p>  <p>\$6.99</p>	<p>Juvenile Fiction</p>  <p>\$15.99</p>		

Best Of

1.  LDS Book Club
LDS - Mormon Scriptures, History, Biography, Reference and More
2.  LOVER AVENGED
3.  Ultimate Classic Library
3,000+ works
4.  MAY BAUGH
At Last Comes Love
5.  Collins English Dictionary
Special offer: Collins Unabridged English Dictionary, 9th Edition + Collins Essential Thesaurus

Vantaggi per gli editori

- Distribuzione immediata in tutto il mondo
- Costi di distribuzione trascurabili
- Il contenuto è protetto dalla duplicazione
- Il diritto di lettura può essere limitato nel tempo
- Il contenuto è visualizzabile in tutto o in parte
- Il contenuto è stampabile o no
- Il contenuto è imm modificabile (ma annotabile)
- Il contenuto è indicizzabile da un motore di ricerca
- Il contenuto è portabile su diverse piattaforme
- Ecologici (non usano carta)
- Magazzino fisico non necessario

Vantaggi per i lettori

- Acquisizione on line
- Nessun peso
- Layout personalizzabile
- Contenuto annotabile
- Autoilluminato
- Servizi accessori (es. dizionario integrato)
- Il contenuto può essere letto da sintetizzatori vocali
- Possono esserci inserti multimediali
- Non si spreca carta, né occorre spazio fisico per conservare il libro

Applicazioni speciali degli ebook

- Conservazione
- Testi fuori stampa
- Libri di testo (universitari, scolastici)
- Manuali operativi

Alcuni modelli di business

- I singoli libri si pagano e scaricano, dopo aver *registrato* il proprio "reader"
- Abbonamento ad una biblioteca digitale
- Print on demand

Esempio

Book Details

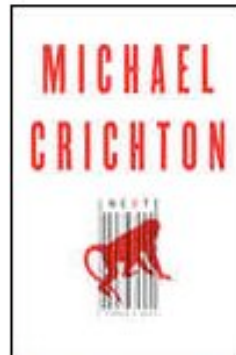

[Preview »](#)

Next

By: Crichton, Michael
Published By: HarperCollins

Adobe Reader Price: \$17.95
Mobipocket Reader Price: \$17.95
Microsoft Reader Price: \$17.95

Adobe Reader

Ebook Extra 1: A Conversation with Michael Crichton, Author of NEXT

Ebook Extra 2: Michael Crichton Next Audio Interview

Ebook Extra 3: This Essay Breaks the Law by Michael Crichton

	MobiPocket Reader	Adobe eBook Reader	Microsoft Reader
	Buy this format >	Buy this format >	Buy this format >
Price	\$17.95	\$17.95	\$17.95
ISBN	0061290424	0061290416	0061290432
Published Date	12/1/2006	12/1/2006	12/1/2006
File Size	339K	2904K	488K
Security	DRM Encrypted	Settings listed below	Owner-Exclusive
Printing	N/A	On, 25 pages can be printed every 7 days.	N/A
Copying	On (90 characters)	On, 25 pages can be copied every 7 days.	Off
Expiry	Off	Off	Off
Lending	Off	Off	Off
Reading Aloud	N/A	On	Off
Minimum Software Version	N/A	N/A	MS Reader 2.1
Suitable Devices	Pocket PC, Palm handhelds, SmartPhones, Tablet PCs, PCs, Laptops	Palm handhelds, Tablet PCs, PCs, Macs, Laptops	Pocket PCs, Tablet PCs, PCs, Laptops

www.lightningsource.com



Lightning Source
The Power of OneSM

[About Lightning](#)

[Services](#)

[Resources](#)

[FAQs](#)

[Site Map](#)

New Ingram Stocking Strategy



Login Name:

Password:



[New Customer?](#)

[Forgot your password?](#)

Copyright © 2000 - 2005.
Lightning Source Inc. All rights reserved.

[Terms of Use](#)
[Privacy Policy](#)

Welcome to Lightning Source . . . We Are On Demand

- ⚡ In 2003, we printed our 10 millionth book
- ⚡ We bring to life more than 30 billion words per month - three new chapters *every second*
- ⚡ In the time it takes to blink, 8 more pages are ready to read
- ⚡ Our delivery channels cover more than 90% of all retail bookstore outlets in the US
- ⚡ Our infrastructure processes over 2,000,000,000,000+ bytes of information *each day*
- ⚡ eBooks fly through our fulfillment system
- ⚡ In one week we manufacture 120,000+ books, *one at a time*
- ⚡ 2,500+ publishers trust us with their content

- ⚡ Our content library maintains 200,000+ orderable titles

We Help You Succeed . . .

One Book at a Time

www.libuk.com

libuk
eBook network

arcana

Libuk free Libuk shop Libuk university Libuk writers i percorsi di Libuk la mia biblioteca carrello

Chi siamo I Partner Gli Editori Le collaborazioni Contatti

ricerca
titolo
autore
ricerca avanzata

Catalogo
Registrazione
Login
Help e FAQ
La mia biblioteca

Get Acrobat®
Adobe eBook Reader

Microsoft
Reader

palm

OVERDRIVE

Benvenuti a **ebookland**

ebookland è il luogo dove lo scrittore incontra l'editore, dove puoi trovare libri gratis, dove seguire percorsi affascinanti sulle tracce dei tuoi autori preferiti

>>

libuk

Quoquo Zuc.
Racconti surreali

libuk

La vita che verrà

libuk

Il senso occulto delle cose

www.lulu.com

Lulu

Guida per gli acquisti durante le feste

Cerca: in **Tutti i prodotti** **VAI**

Loggati | Iscriviti | Carrello della spesa

Pubblica | Acquista | Vendi | Comunità | Il mio Lulu | Aiuto **In visita la prima volta >**

Pubblica

il tuo libro, la tua arte.
Per divertimento o per guadagnare.

Sciogli le briglie della tua creatività >

Vendi

le tue opere ad acquirenti provenienti da oltre 80 paesi del mondo.

Monetizza le tue idee >

Collegati

alla più grande comunità di scrittori online.

Cosa ne pensa la gente >

ilmiolibro.kataweb.it

- 1500 euro per 100 copie da 250 pagg ciascuna con copertina rigida
- 15 euro per una copia

Aspetti editoriali

- Gestione dei diritti
 - Contenuto crittografato
 - Confronto con Napster e Mp3
 - I sistemi attuali sono molto restrittivi
 - Il contenuto è scarsamente manipolabile.
 - Condivisione impossibile
- Distribuzione
 - Editori digitali
 - Librerie digitali (Es. Amazon)
 - Volumi scarsi

Distribuzione

- BarnesandNoble
 - Acrobat Reader and MS Reader
- Amazon
 - MS Reader
- Ebook Specialty Shops
 - MightyWords (ex Ematter)
 - “Vanity Cyberpresses”

Modello self-publishing

Una casa editrice per **self-publishing** fornisce servizi di authoring (es. copy-editing) e distribuzione (on line o print on demand). Esempi:

- Lulu www.lulu.com
- iUniverse www.iuniverse.com
- AuthorHouse www.authorhouse.com
- Xlibris www.xlibris.com

Modello della biblioteca digitale in abbonamento

Ebooks server side

- Questia www.questia.com 20\$/mese
- Books24x7 www.books24x7.com
- ITKnowledge www.earthweb.com
- NetLibrary www.netlibrary.com
- Ebrary www.ebrary.com

Safari di O'Reilly

- O'Reilly Technical Library and Book Catalog
 - Versioni digitale e cartacea: identiche
 - Searching gratis
 - Abbonamento (\$43 al mese)
 - 5 download per mese gratis
 - 35% sconto sulla versione stampata

Formati per ebook

La prima generazione

- .lit formato proprietario Microsoft Reader
- .pdf formato di Adobe, standard internazionale

Formati speciali

- Isilo, Tk3, Plucker, CHM, djvu

La nuova generazione basata su OEB (precisamente più OEBPS, una variante XHTML)

- .mobi (e .prc) Mobipocket reader
- .epub Adobe Digital Editions e altri

Creare un e-book

- Molto semplice (ma dipende dal formato), occorre avere lo strumento giusto
 - Microsoft E-book Authoring Plug-in
 - Palm E-book Dropbook
 - Acrobat distiller plug-in
- In genere sono strumenti che effettuano (in modo opaco all'autore) varie manipolazioni basate su un linguaggio di markup

Microsoft Reader

- Lettore software su Windows e PocketPC
- Tecnologia di fonti ClearType
- Usa il formato OpenEBook per il sorgente
- Versioni con funzioni diverse per PC e PocketPC
- Gratis

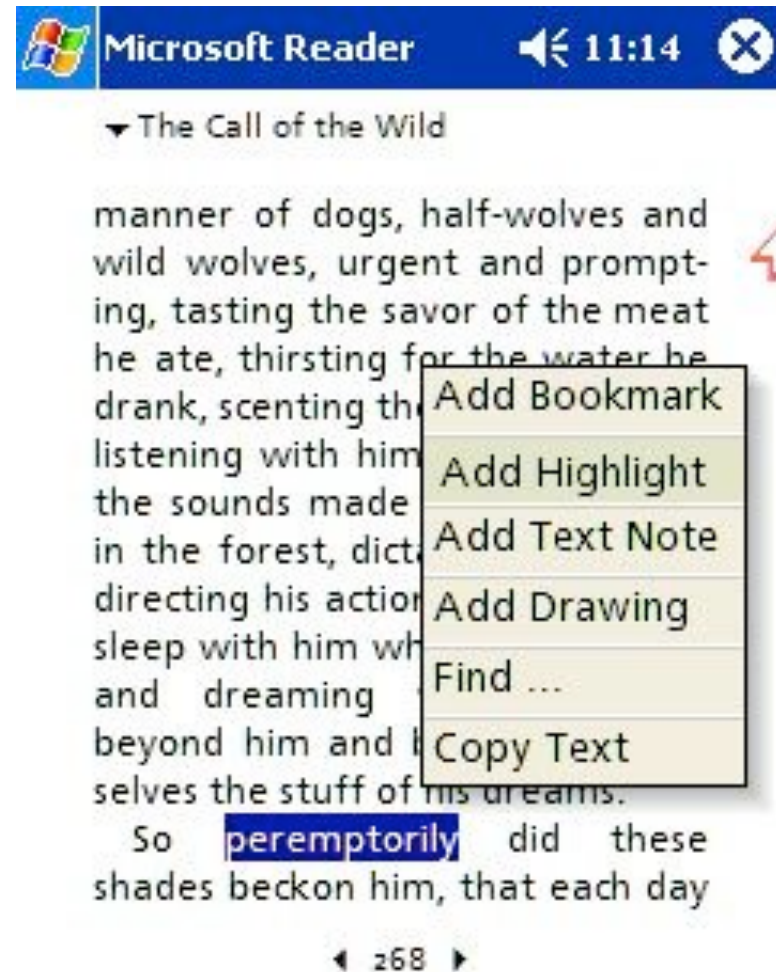

Reader plugin per MS Word

- Creare o aprire un documento con MS Word (solo su Windows)
- Formattare il testo a piacere
- Click il bottone icona “Reader”
- Aggiungere i metadati
- Click “OK”

Creare un ebook per MS Reader

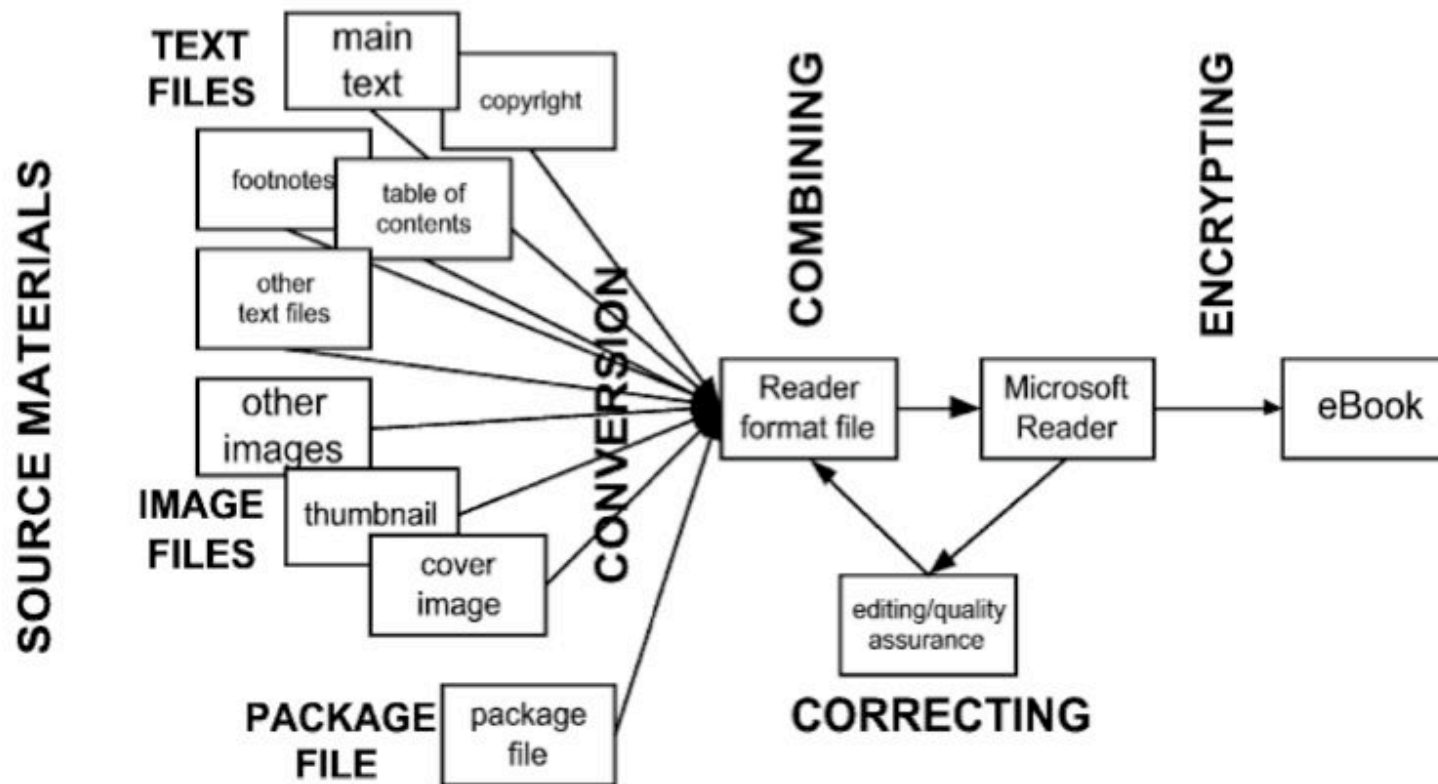

Ciclo di vita

- Il ciclo di vita di un ebook inizia dalla scrittura del testo e dalla progettazione del layout
- Supponendo di usare MS Word per il testo, resta il problema del controllo del layout (page o flow view?)
- Una volta creata la visione logica del contenuto, occorre prepararlo per la distribuzione in formato ebook mediante un programma *compilatore di ebook*
- Occorre infine distribuire l'ebook in modo da garantire la riscossione dei diritti d'autore, mediante un Content Management System (CMS) che offra funzioni di Digital Rights Management (DRM)

Software per creare .LIT

- ReaderWorks di Overdrive
 - www.overdrive.com
 - Standard: gratis
 - Publisher: 119\$
 - SDK: 2000\$

Acrobat Reader

- Lettore software
 - Windows
 - Macintosh
 - PocketPC
 - Linux
- Basato su PDF
- gratis

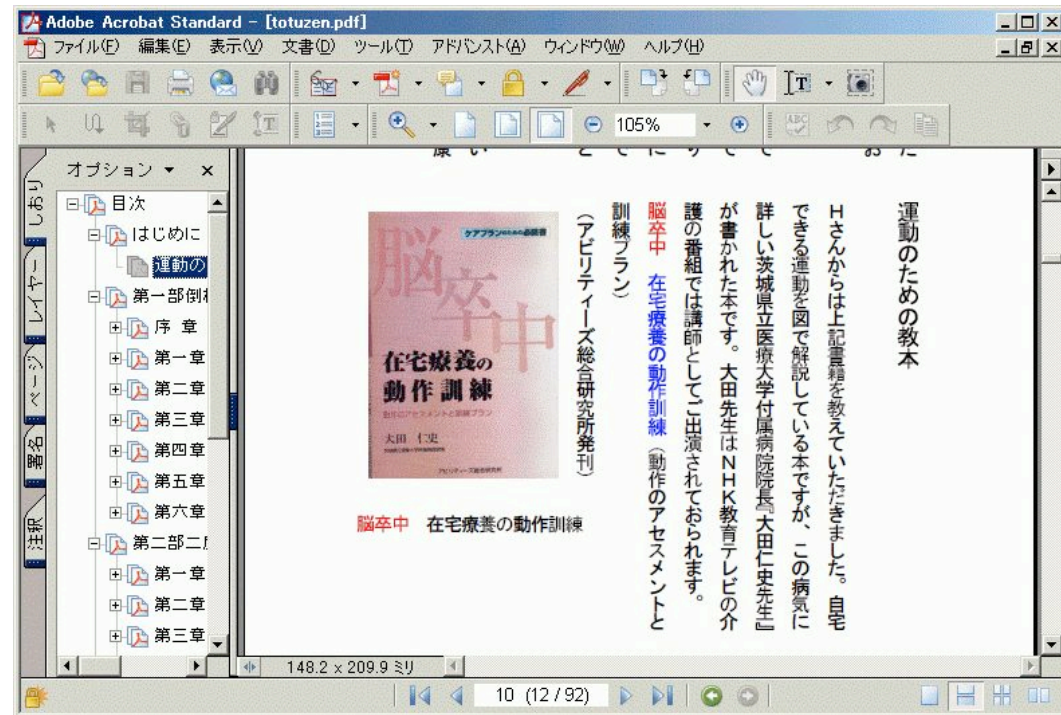

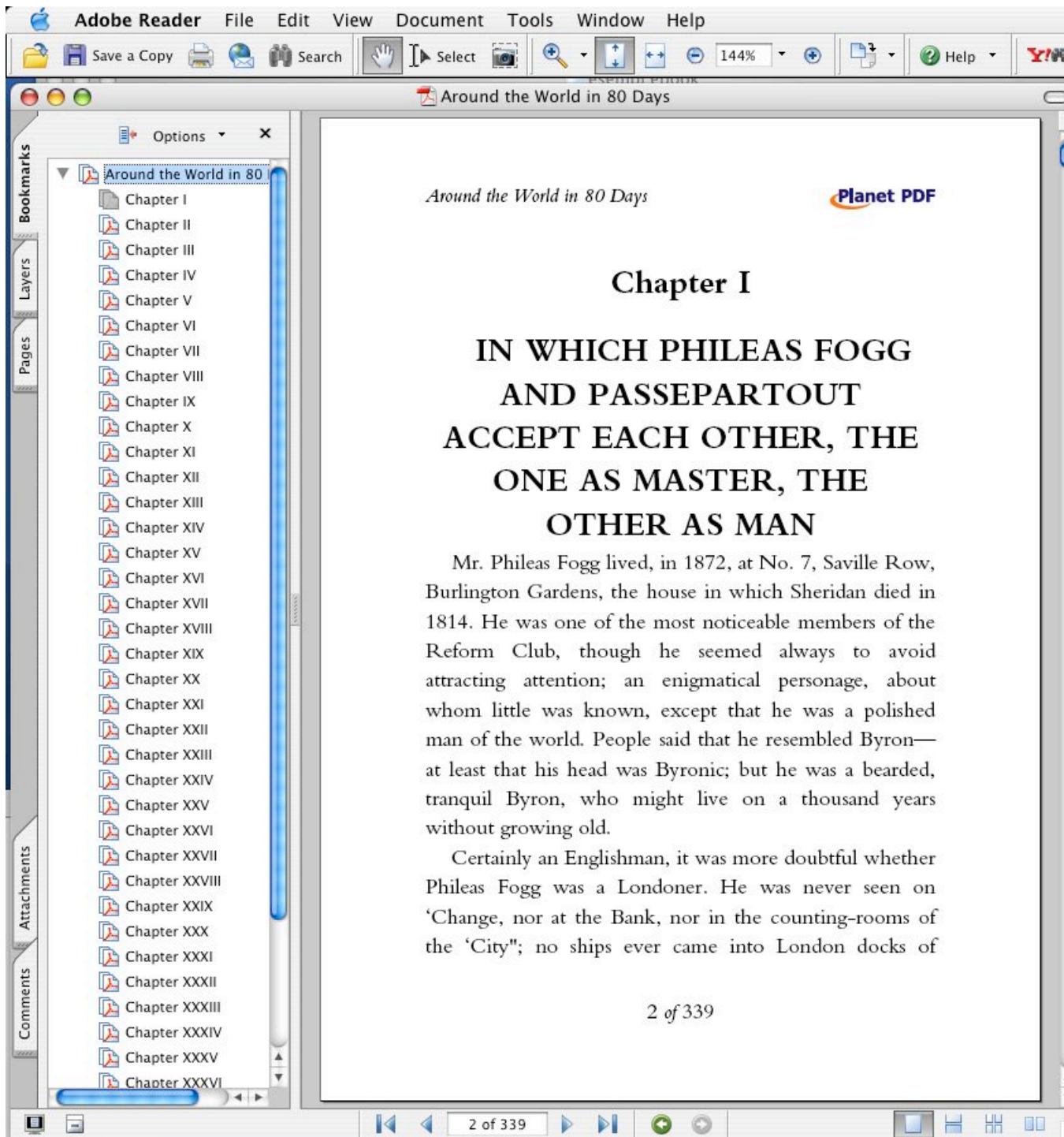

Around the World in 80 Days

Planet PDF

Chapter I

IN WHICH PHILEAS FOGG AND PASSEPARTOUT ACCEPT EACH OTHER, THE ONE AS MASTER, THE OTHER AS MAN

Mr. Phileas Fogg lived, in 1872, at No. 7, Saville Row, Burlington Gardens, the house in which Sheridan died in 1814. He was one of the most noticeable members of the Reform Club, though he seemed always to avoid attracting attention; an enigmatical personage, about whom little was known, except that he was a polished man of the world. People said that he resembled Byron—at least that his head was Byronic; but he was a bearded, tranquil Byron, who might live on a thousand years without growing old.

Certainly an Englishman, it was more doubtful whether Phileas Fogg was a Londoner. He was never seen on 'Change, nor at the Bank, nor in the counting-rooms of the 'City"; no ships ever came into London docks of

Adobe, PDF e Acrobat

- PDF formato orientato al layout di pagina
- Acrobat è un programma permette di creare/editare ebook
- Adobe investe molto sulle tecnologie per ebook
 - Adobe [Ebooks Central](#)
 - Tecnologia CoolType (simile a ClearType di Microsoft)
 - Digital Rights Management

DRM di PDF: il caso di Alice

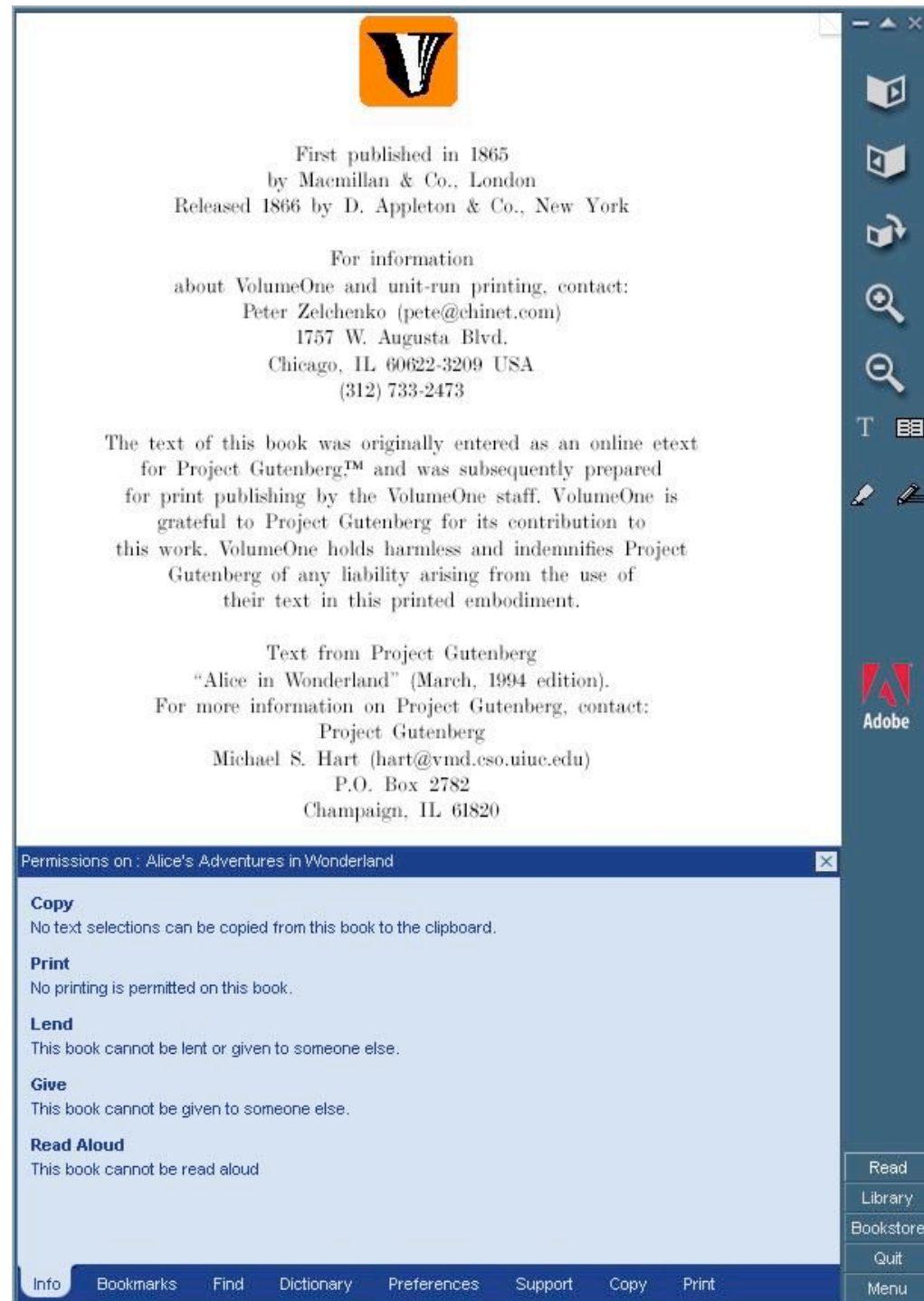

The screenshot shows a PDF viewer window displaying the title page of 'Alice's Adventures in Wonderland'. The page features a logo at the top center, followed by publication information: 'First published in 1865 by Macmillan & Co., London' and 'Released 1866 by D. Appleton & Co., New York'. It then provides contact information for VolumeOne, including Peter Zelchenko's email and address in Chicago. A paragraph explains that the text was originally from Project Gutenberg and is now in a printed format. Another paragraph provides contact information for Project Gutenberg, including Michael S. Hart's email and address in Champaign, IL. A permissions dialog box is open at the bottom, listing restrictions: 'Copy' (no clipboard), 'Print' (no printing), 'Lend' (cannot be lent), 'Give' (cannot be given), and 'Read Aloud' (cannot be read aloud). The viewer's interface includes a toolbar on the right with icons for navigation and search, and a menu bar at the bottom with options like Info, Bookmarks, Find, Dictionary, Preferences, Support, Copy, Print, Read, Library, Bookstore, Quit, and Menu.

First published in 1865
by Macmillan & Co., London
Released 1866 by D. Appleton & Co., New York

For information
about VolumeOne and unit-run printing, contact:
Peter Zelchenko (pete@chinet.com)
1757 W. Augusta Blvd.
Chicago, IL 60622-3209 USA
(312) 733-2473

The text of this book was originally entered as an online etext
for Project Gutenberg™ and was subsequently prepared
for print publishing by the VolumeOne staff. VolumeOne is
grateful to Project Gutenberg for its contribution to
this work. VolumeOne holds harmless and indemnifies Project
Gutenberg of any liability arising from the use of
their text in this printed embodiment.

Text from Project Gutenberg
"Alice in Wonderland" (March, 1994 edition).
For more information on Project Gutenberg, contact:
Project Gutenberg
Michael S. Hart (hart@vmd.cso.uiuc.edu)
P.O. Box 2782
Champaign, IL 61820

Permissions on : Alice's Adventures in Wonderland

Copy
No text selections can be copied from this book to the clipboard.

Print
No printing is permitted on this book.

Lend
This book cannot be lent or given to someone else.

Give
This book cannot be given to someone else.

Read Aloud
This book cannot be read aloud.

Info Bookmarks Find Dictionary Preferences Support Copy Print Read Library Bookstore Quit Menu

Altri software: iSilo

- Formato proprietario
- Lettore per Palm, PocketPC e Windows
- Funziona anche su alcuni cellulari

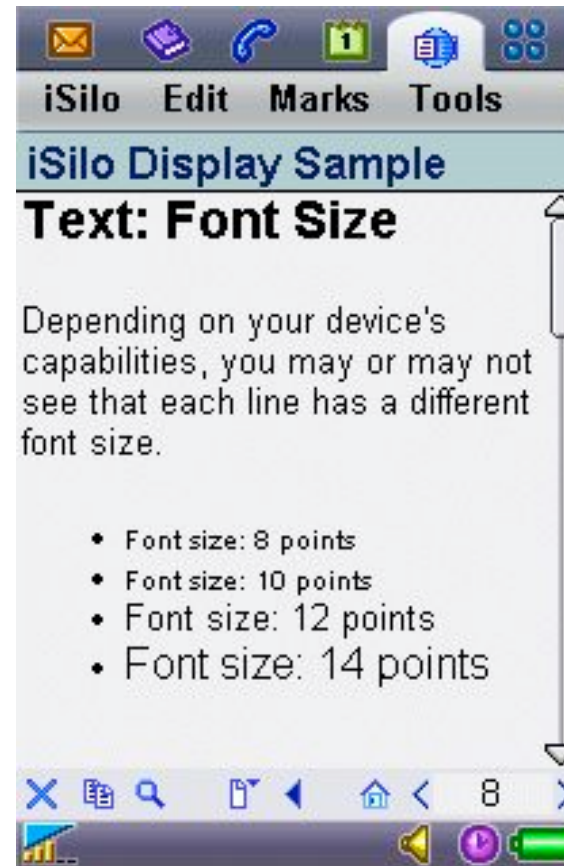

Altri software: NightKitchen

- Formato TK3
- Offre strumenti per creare ebook
- Ebook Reader su varie piattaforme
- Gratis sia il lettore sia il compilatore
- `nightkitchen.com`

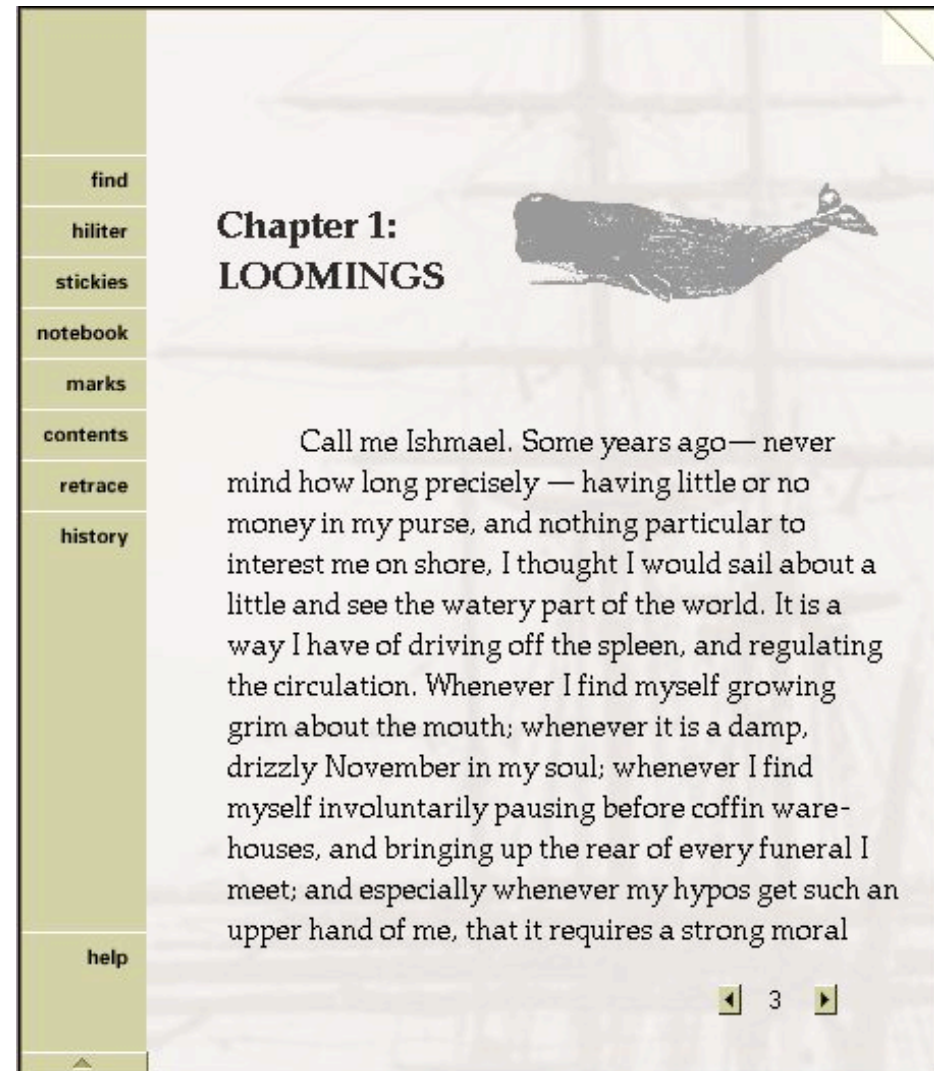

TK3

- TK3 supporta molti tipi di file:
 - testuali: RTF e HTML
 - Grafici: JPEG, GIF, PICT e BMP
 - Audio/Video: WAV, AIFF, QuickTime, AVI, MIDI
- www.easymediabroadcast.com/EBooksAF.htm

Verso gli standard

- **Open ebook** (OEB) era uno standard aperto basato su XML (in realtà XHTML)
- .epub è un formato derivato da OEB
- .lit è un formato Microsoft basato su HTML compresso

OeBF: Open e-Book Forum

- www.openebook.org
- Definisce un formato standard per l'industria degli ebook
- OEBFForum: Consorzio internazionale
- Organizzazione indipendente
- Oggi si chiama IDPF

Membri IDPF

- Editori: Random House, HarperCollins, AOL Time Warner Book Group, McGraw-Hill, St. Martin's Press, Simon & Schuster, Elsevier Science etc.
- Aziende tecnologiche: Microsoft, Adobe, Palm Digital Media, OverDrive etc.
- Gruppi: Daisy Consortium, RFB&D etc.
- Altre associazioni: AAP, ALA

Evoluzione dello standard OEB

- **Versione 1.0 OEPBS –9/1999**
 - Accuratezza di presentazione su diversi formati ebook
 - Un formato, lettori multipli su diverse piattaforme tecnologiche
- **OEPBS 1.0.1 – 6/2001**
 - Piccole correzioni
- **OEPBS 1.2 – 8/2002**
 - Controllo della presentazione migliorato
 - Markup sottoinsieme stretto di XHTML 1.1
 - Miglior controllo CSS
- **OEPBS 2.0 = EPUB - 9/2007**

.epub

- **".epub"** è l'estensione di un formato XML per ebook con layout "liquido" (reflowable)
- Standard aperto definito IDPF
- **Include tre standard: Open Publication Structure (OPS), Open Packaging Format (OPF) e Open Container Format (OCF)**
- **".epub"** permette agli editori di produrre un unico file che i clienti possono fruire su diversi lettori software o hardware
- **"OEBPS"**, nato nel 1999, è il precursore di OPS

Lettori sw per .epub

- Adobe Digital Editions
- Mobipocket
- Lexcycle Stanza
- FBReader (open source)
- Openberg Lector (open source)

Requisiti Open Ebook

- Ricchezza tipografica
- Adattabilità su schermi a piccola risoluzione (reflow)
- Accessibilità
- Internazionale e multilingua
- Funzioni DRM
- Aperto
- Compatibile con XML

OEB Publication Structure (OEBPS)

- Obiettivo: permettere di produrre a minor costo ebook più ricchi di funzioni
- Formato basato su XML per il contenuto degli ebook
- Combina vari standard: html, xml, xhtml, CSS, Unicode, ecc., in un "package" OEBPS
- Standard accettato da vari strumenti: PageMaker, InDesign, Quark verso Palm, Microsoft .lit, PDF

OEB Publication Structure

- Definisce la specifica di struttura di un ebook
- Usa XML, HTML e CSS (XHTML 1.1 ristretto)
- Una pubblicazione OEBPS contiene cinque diversi tipi di file: OEB package, OEB document, CSS, PNG e JPEG
- Si possono includere anche altri tipi di file

OEBPS

- OEBPS 1.2 - 2002
 - OEB package DTD
 - Metadata, Manifest, Spine, Tours, Guide
 - OEB document DTD
- Tecnologie
 - XML (sintassi)
 - HTML (presentazione)
 - CSS (stile)
 - Dublin Core (metadata)

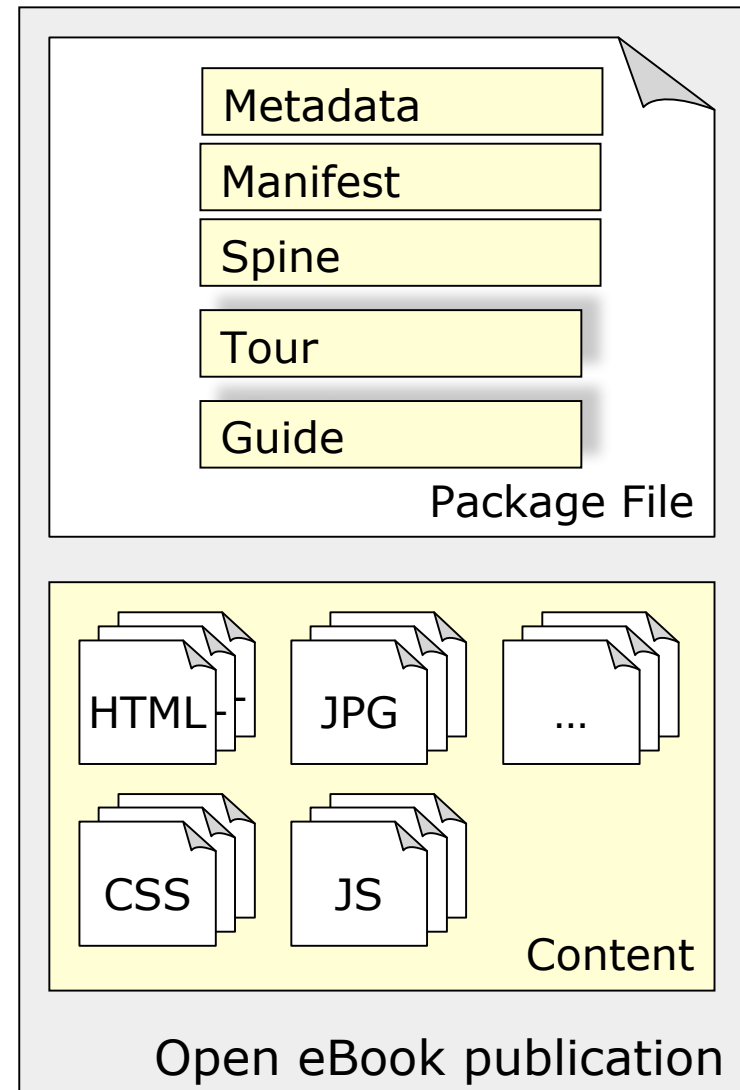

Costruire un ebook

- Determinare i formati target
 - Formati a pagina o formati a flusso
- Preparazione
- Conversione
- Confezione
- Consegna

Determinare i formati target

- Determinare i formati necessari decidendo su quali canali verrà diffuso l'ebook
- Decisione basata su fattori quali:
 - Tipo del contenuto (romanzo, articolo accademico, di nicchia [viaggi], ecc.)
 - Mercato (generico, specializzato, libreria)
 - Budget
- Decisione importante: formato a pagina vs formato a flusso
 - Un formato a pagina (es. PDF) è più semplice
 - I formati a flusso richiedono più lavoro

Page View vs. Flowed View

- “**Page View**” è la vista che associamo a pagine tipiche: di libro, di rivista o di altro materiale di lettura
 - Page view è influenzata dai monitor contemporanei (desktops/laptops)
 - Assente o comunque inutile su PDA o cellulari (ma la loro risoluzione sta aumentando)
 - I nuovi TabletPC rendono la lettura più semplice
- “**Flowed View**” è la vista tipica di un browser: lunghe schermate di testo ridimensionabile, che “fluisce” in larghezza e in altezza
 - Vista ideale per il testo
 - Inadatta per colonne multiple o per layout complessi
 - La qualità delle immagini fotografiche o vettoriali può deteriorarsi in ambiente browser
 - Su piccoli schermi la leggibilità scade molto

Formati a pagina

- PDF (Portable Data Format)
 - Standard di fatto posseduto e pubblicato da Adobe
 - Visibile con Adobe Reader o plugin
 - Varianti di PDF (es. Atmosphere) sono fruibili con plugin o applicazioni specifiche
 - Tutti i componenti del documento sono in binario – immagini, fonti, linee
- Djvu
 - Formato proprietario
 - Visibile con lettore sw o browser plugin

Formati a flusso

- HTML
 - W3C Standard
 - Tutti i browser lo supportano: IE, Safari, Netscape, Firefox
 - Testo limitato alle fonti dell'host
- OEB (Open eBook)
 - OEB Standard – basato su XHTML
 - Dopo conversione, visibile nei formati “eBook” :
 - Microsoft Reader (LIT)
 - MobiPocket (PRC, MOBI)
 - EPUB
 - Usato nei sistemi online
 - netLibrary (nIOEB)
 - Baker & Taylor (BT-OEB)
- Altri
 - Palm Reader

Creare un Open Ebook

- Conversione da .pdf o da .doc
 - Word2OEB possibile via HTML export + editing
 - Quark/altro richiedono text export + scripts
 - eBook Export Xtension di QuarkXPress
 - conversione automatica
 - Stanza di Lexcycle
 - TextCafe di Texterity (strumento costoso)
www.texterity.com/artstech/textcafe/
- Strumenti speciali se si converte a formato specifico
 - Palm - Palm eBook Studio
 - Microsoft LIT - Microsoft Reader add-in di Word

Conversione di formato

- Conversione da OEB a vari formati
 - OEB è uno standard, ma viene interpretato in modo diverso
 - HTML: già XHTML, occorre qualche modifica per i browser
 - Microsoft Reader: Usa OEB standard
 - MobiPocket: sottoinsieme OEB (non supporta tutti gli stili)
 - netLibrary OEB: Page Oriented (richiede page break)
 - Baker & Taylor ED-OEB: Page Oriented (richiede page break)
 - Palm dopo conversione, o con tag HTML
- Preparazione di versioni speciali
 - Estratti di capitoli, o eBook promozionali

Il processo

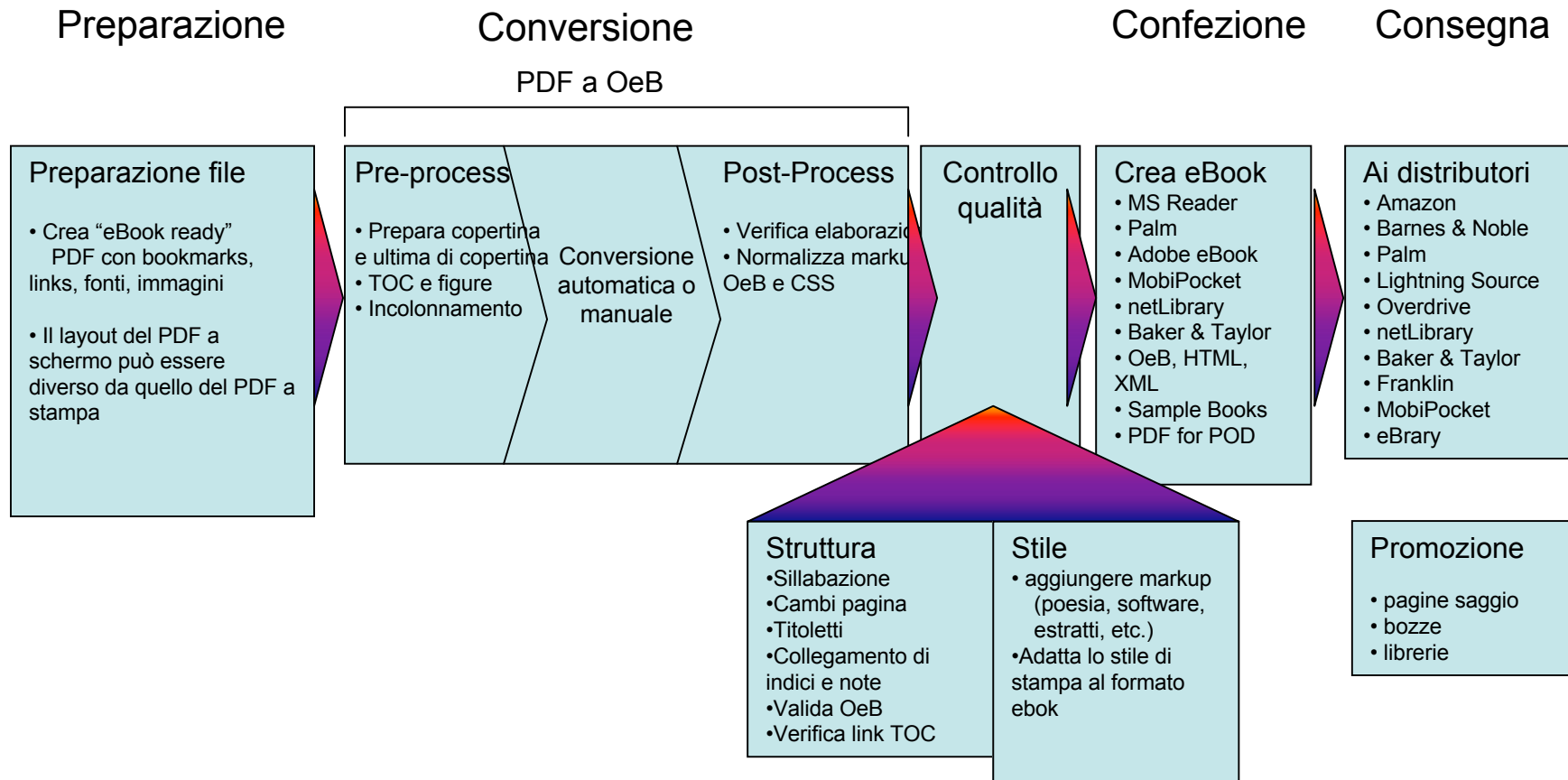

Conclusioni

- Ebook: un'utopia che deve fare ancora molta strada
- Ebook hardware: prima generazione fallita, nuova generazione in arrivo in Cina e altri paesi asiatici
- Ebook software: XML e PDF dominano le filiere editoriali digitali

Esercizio

- Progettare e creare un ebook
 - Usare un testo già esistente, possibilmente con figure
 - Usare un programma di creazione di ebook, per esempio Book Designer

Riferimenti

- C. Doctorow, *Ebook, ovvero né E né Book*, 2004, trad. it. Apogeo on Line
- B. Patino, Rapport sur le livre numerique, 2008
- C. Armstrong, Virtual there? eBooks in UK academic libraries, *Program, electronic library and information systems*, 36:4(216-227), 2002
- J. Cox, E-Books, Challenges and Opportunities, *D-Lib Magazine*, 2004
<http://www.dlib.org/dlib/october04/cox/10cox.html>
- J. Littman & L. Connaway, A Circulation Analysis of print books and ebooks in an academic research library, *Library Resources and Technical Services*, 48:4(256-262), 2004 www.oclc.org/research/publications/archive/2004/littman-connaway-duke.pdf
- <http://www.subscription-agents.org/conference/200802/Inger.pdf>
- <http://www.sic.ox14.com>

Siti

- www.openebook.org
- www.idpf.org
- www.fonerbooks.com/
- www.adobe.com/epaper/ebooks/main.html
- www.baen.com/
- www.e-book-awards.com/
- www.ebookmall.com
- www.planetebook.com
- www.bookzone.com/bookzone/ebookfaq.html
- www.lib.rochester.edu/main/ebooks/index.htm

Blog

- ebook-reader.blogspot.com
- ebook.simonsaysblogs.com
- www.teleread.org/blog
- wowio.wordpress.com

Esempi

- www.hxa7241.org/books/books.html
- www.ebookgratis.it

Domande?

© Cartoonbank.com



"Well, instead of discussing the book we could discuss why none of us had time to read it."